

TRU-FLEX METAL HOSE CORP. is an  
"ISO Registered Company"

---

---

## Installation/Training Guide **PRO-FLEX® CSST**

Patented System #5,845,946, #5,857,716 &  
#6,102,445 and other patents pending

2391 S. St. Rd. 263  
PO Box 247  
West Lebanon, Indiana 47991

1-800-255-6291 or 765-893-4403 • Fax: 765-893-4114

website: <http://www.tru-flex.com/>  
e-mail: [truflex@tru-flex.com](mailto:truflex@tru-flex.com)



# PRO-FLEX® CSST

## Training Guide and Installation Manual

### TABLE OF CONTENTS

- 1.0 INTRODUCTION**
  - Guidelines Limitations of Manual .....1, 2
  - Applicable Codes & Standards .....3
  
- 2.0 DESCRIPTION OF SYSTEM AND COMPONENTS**
  - System Components .....4, 5, 6  
(Tubing, Fittings, Striker Plates, Pressure Regulators,  
Manifolds, Shut-off Valves, Other Components)
  
- 3.0 SYSTEM CONFIGURATIONS**
  - System Configurations.....7
  - Series Layout & Parallel Layout (low pressure).....8
  - Dual Pressure Layout .....8
  - Multiple Manifold Systems & Combination Steel/CSST System, Elevated Pressure System....9
  - Determine Pressure System .....10
  
- 3.2 SIZING METHODS & EXAMPLES**
  - Low Pressure System (longest length method) (example #1).....11
  - Medium Pressure System (example #2) .....12
  - Elevated Dual Pressure System (example #3).....13
  - Combination Steel / CSST System.....14
  
- 4.0 INSTALLATION PRACTICES / GUIDELINES**
  - General Installation Guidelines.....15, 16
  - Minimum Bend Radius .....15
  - Support .....15
  
- 4.2 FITTING ASSEMBLY**
  - Assembly and Re-assembly Procedures .....17
  - Tubing Cutting / End Preparation.....17
  - Minimum Tightening Torque .....18
  - Termination Outlet Configurations .....18
  
- 4.3 ROUTING**
  - Vertical Runs.....19
  - Horizontal Runs.....19
  - Indoor / Outdoor Issues .....19
  - Clearance Holes & Notching.....20
  - Concealed Locations for Fittings.....21
  
- 4.4 PROTECTION**
  - Striker Plate Requirements.....22, 23
  - Spiral Metal Hose Requirements .....22, 23
  - Outdoor Installations.....22, 23
  - Metal Wall Studs Installation .....23

<b>4.5</b>	<b>CONNECTIONS</b>	
	Meter Hook-ups .....	24, 25
	Fixed Appliance.....	26
	Moveable Appliance .....	26
	Pad Mounted Appliance.....	26
	Gas Fireplace Installations .....	27
	Fire Rated Construction through Plenums and Installations within a chase.....	27
	Electrical Bonding .....	28, 29
	BBQ Gas Grill – Stationary.....	30
	BBQ Gas Grill – Moveable .....	30
	Gas Lamps.....	30
	Ceiling or Wall Hung Infrared Heaters.....	30
	CSST Buried Under Concrete Slab.....	31
	CSST Embedded in Concrete Slab .....	31
	Supporting of Conduit Embedded in Reinforced Slab.....	31
	Short (2 to 6 ft) Outdoor Roof Mounted Installations.....	32
	Long Length Outdoor Roof Mounted Installations.....	32
	Two Examples of Appliance Termination / Stub-out .....	32
	Extending Existing CSST Tubing Run .....	32
<b>4.6</b>	<b>MANIFOLD STATIONS</b>	
	Allowable Locations / Configurations .....	33
<b>4.8</b>	<b>PRESSURE REGULATORS</b>	
	Installation / Sizing Requirements .....	34
	Vent Limiter Option.....	35
	Vent Line and Sizing Requirements.....	36
	Adjustments .....	36
<b>5.0</b>	<b>INSPECTION / REPAIR / REPLACEMENT</b>	
	Inspection and Testing of Installed CSST.....	37
	Pressure Testing and Inspection Procedures .....	37
	Appliance Connection Leakage Check Procedure .....	38
	Repair / Replacement of Damaged CSST Tubing .....	39, 40
<b>6.0</b>	<b>SIZING TABLES (Natural Gas and LP Gas)</b>	
	Natural Gas – Low Pressure to Medium Pressure .....	41, 42
	Natural Gas – Elevated Pressure .....	43
	Natural Gas – 5 psig.....	44
	Propane Gas .....	45, 46
	Iron Pipe Capacity Table.....	47
	Referenced Data .....	48
<b>7.0</b>	<b>TECHNICAL DATA SPECIFICATION SHEET</b> .....	49
<b>8.0</b>	<b>CSST INSTALLATION CHECK LIST</b> .....	50
<b>9.0</b>	<b>DEFINITIONS OF TERMINOLOGY</b> .....	51
<b>9.2</b>	<b>WARRANTY INFORMATION</b> .....	52
	<b>NOTES</b> .....	53, 54
	<b>QUALIFIED INSTALLER CARD</b> .....	Inside Back Cover

# 1.0 Introduction

**This installation/training guide is designed to assist a Pro-Flex® qualified installer in the methods and procedures for the installation of flexible gas piping (CSST). The installer must also meet all qualifications required by the state and/or local administrative authority administering the provisions of the code where the gas piping is installed.**

It would be impossible for this guide to anticipate and cover every possible variation in housing configurations and construction styles, appliance loads and local code requirements. Therefore, there will be applications that are not covered in this document. The user should exercise good judgement on system design and installation, or seek technical input from other qualified sources.

**Where a conflict exists between this guide and local requirements the local codes shall take precedence. The installation shall be made in accordance with local codes, or, in the absence of local codes, in accordance with the National Fuel Gas Code, ANSI Z223.1 / NFPA 54, Natural Gas and Propane Installation Code, CSA B149.1, the International Fuel Gas Code, the Federal Manufactured Home Construction and Safety Standards, 24 CFR Part 3280, the Manufactured Housing Construction and Safety Standards, ICC / ANSI 2.0, or the Standard on Manufactured Housing, NFPA 501, as applicable.**

**Special attention must be given to the proper design, installation, testing and use of the gas piping. Sound engineering, principles and practices must be exercised, as well as diligent adherence to the proper installation procedures. All installed systems must pass customary installation inspections by the administrative authority prior to being placed in service.**

**Improper installation or operation of the system may result in fire, explosion, or asphyxiation. Only the components provided or specified by Tru-Flex Metal Hose Corp., for the use of Pro-Flex® as part of the fuel gas system are to be used in the installation. Use of components from other flexible gas piping systems other than those specified as part of the Pro-Flex® piping system is prohibited and may result in poor system performance and serious bodily injury or property damage.**

**The installation instructions and practices outlined in this training guide only apply to the use of Pro-Flex® CSST flexible gas piping systems. Tru-Flex Metal Hose Corp., assumes no responsibility for installations made with other manufacturers flexible gas piping systems.**

**This installation/training guide has been written in accordance with the most current edition of the following standard:**

**“ANSI LC1a – 2009, CSA 6.26a – 2009 and ANSI LC – 1 – 2005, CSA 6.26 – 2005”  
“Fuel Gas Piping Systems Using Corrugated Stainless Steel Tubing (CSST)”**



This standard applies to natural and propane gas piping systems using corrugated stainless steel tubing (CSST), intended for installation in residential, commercial or industrial building including the following components as a minimum:

- a) Corrugated stainless steel tubing (CSST)
- b) Fittings for connection to the CSST
- c) Striker plates and/or protective conduit to protect the installed CSST from puncture threats

Other Components of piping systems covered in this standard include gas manifolds, gas pressure regulators. If such additional components are required to complete the gas piping installation, they shall be either be provided as part of the piping system or specified in this Pro-Flex® CSST Installation/Training Guide.

- **Pro-Flex®** Fittings are tested for concealment (subject to local code approval)
- **Pro-Flex®** can be routed in most locations where traditional rigid gas piping materials are installed:
  - \* Inside hollow wall cavities and through walls
  - \* Beneath or through floor and ceiling joists
  - \* On top of ceiling joists in an attic space
  - \* Outside of a building to gas meters and propane supply tanks
- **Pro-Flex®** has been tested and listed by CSA (formerly American Gas Association) for outdoor use.
- **Pro-Flex®** can be used with all fuel gases recognized in the NFPA 54 National Fuel Gas Code up to a maximum ANSI/CSA LC-1 listed operating pressure of 5 psi (34.5 kPa). The maximum actual operating pressure, including transients, shall not in any case exceed 6.5 psi (44.8 kPa).
- **Pro-Flex®** can be used in combination with all approved fuel piping materials for new construction and for replacing and retrofitting existing piping installations. All **Pro-Flex®** mechanical joint fittings terminate in a standard NPT male pipe thread which allows for attachment to valves, unions and couplings.
- For underground burial and embedded in concrete, (CSST) flexible gas piping must be routed within a non-metallic, water tight conduit. No mechanical joint fittings are permitted within the conduit.
- **Pro-Flex®** may be connected directly to FIXED appliances (subject to local code approval). Flexible appliance connectors (such as Tru-Flex's Home-Flex® gas connectors) must be used to connect to a moveable gas appliance.
- When using **Pro-Flex®**, precautions should be taken to ensure any exposed tubing is not damaged or abused during building construction or reconstruction.



# Applicable Codes & Standards

## ATTENTION

The installation of **PRO-FLEX**® Corrugated Stainless Steel Tubing (CSST) must be performed by a qualified installer who has been trained in the use of the **Pro-Flex**® system. The installer must also meet all qualifications required by the state and/or local administrative authority administering the provision of the code where gas piping is installed.

This Installation/Training Guide provides the user with a general guidance when designing and installing fuel gas piping systems using **PRO-FLEX**® CSST gas piping. This guideline must be used in conjunction with all local building codes. Local requirements will take precedence in the event there is a conflict between the guideline and the local codes. The installation shall be made in accordance with local codes, or, in the absence of local codes, in accordance with National Fuel Gas Code, ANSI Z223.1/NFPA 54, Natural Gas and Propane Installation Code, CSA B149.1 & B149.2 in Canada, the International Fuel Gas Code, the Federal Manufactured Home Construction and Safety Standard, 24 CFR Part 3280, the Manufactured Housing Construction and Safety Standards, ICC/ANSI 2.0, or the Standard on Manufactured Housing, NFPA 501, as applicable.

Special attention must be given to the proper design, installation, testing and use of the gas piping system. Sound engineering principles and practices must be exercised, as well as diligent adherence to the proper installation procedures. All installed systems must pass customary installation inspections by the administrative authority prior to being placed in service.

### WARNING!

**Improper installation or operation of the system may result in fire, explosion, or asphyxiation. Only the components provided or specified by Tru-Flex Metal Hose Corp., for the use of Pro-Flex® as part of the fuel gas system are to be used in the installation. Use of components from other flexible gas piping systems other than those specified as part of Pro-Flex® system is prohibited and may result in poor system performance and serious bodily injury or property damage.**



## APPLICABLE CODES & STANDARDS

### Standards:

- ANSI LC1a-2009, CSA 6.26a-2009  
ANSI LC1-2005 and CSA 6.26-2005, "Fuel Gas Piping Systems Using Corrugated Stainless Steel Tubing (CSST)."

### Listings:

- CSA – CSA International – Certificate #189768 - #1174673
- IAPMO – International Association of Plumbing & Mechanical Officials - File #3669

### Code Compliances:

- ANSI/CSA LC-1-2005 Fuel Gas Piping Systems Using Corrugated Stainless Steel Tubing
- National Standard of Canada - National Gas & propane Installation Code, CAN/CGA-B149.1 & 149.2
- NFPA – National Fuel Gas Code (NFPA 54)
- NFPA – National Fuel Gas Code (NFPA 58 Standard for Storage and Handling of LP [Liquified Petroleum Gasses] Gas Code)
- BOCA – National Mechanical Code
- CABO – 1 & 2 Family Dwelling
- SBCCI – Southern Building Code Congress International "standard gas code"
- ICC – International Mechanical Code
- IAPMO – International Association of Plumbing and Mechanical Officials - File #3669
- UPC – Uniform Plumbing Code
- UMC – Uniform Mechanical Code

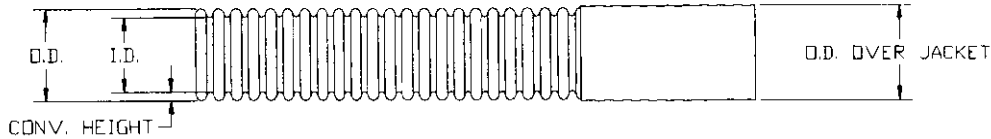
While every effort has been made to prepare this document in accordance with all regional model codes in effect at its printing, Tru-Flex Metal Hose Corp., cannot guarantee that the local administrative authority will accept the most recent version of these codes. It is the ultimate responsibility of the qualified installer to determine suitability and acceptance of any building components including gas piping. **Tru-Flex Metal Hose Corp., manufactures of Pro-Flex® CSST assumes no responsibility for labor or material for installations made without prior determination of local code authority acceptance.**

# 2.0 Description of System and Components

## PRO-FLEX® GAS PIPING SYSTEMS

(Patented #5,845,946, #5,857,716 and #6,102,445 & other patents pending)

### PRO-FLEX® CONSISTS OF THE FOLLOWING:



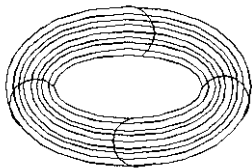
ProFlex® is manufactured in 3/8", 1/2" and 3/4" diameters and available in 25 ft, 50 ft, 75 ft and 225 ft coils. 1" diameter available in 25 ft, 50 ft, 75 ft and 150 ft coils. 1 1/4" diameter available in 150 ft. coil.

### CSST CORRUGATED STAINLESS STEEL TUBING WITH POLYETHYLENE JACKETING

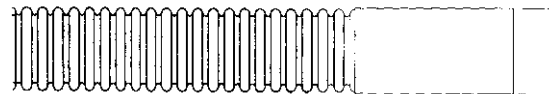
PRO-FLEX® Part Number	PFCT-3875 (10mm)	PFCT-1275 (15mm)	PFCT-3475 (20mm)	PFCT-0175 (25mm)	PFCT-0114 (31mm)
Size	3/8"	1/2"	3/4"	1"	1 1/4"
EHD Size	15	18	25	31	37
Outside Diameter (OD)	.600"	.700"	1.001"	1.24"	1.6"
Inside Diameter (ID)	.450"	.510"	.780"	1.070"	1.29"
Outside Diameter Over Jacket (O.D. Over Jacket)	.635"	.745"	1.046"	1.302"	1.65"

### PRO-FLEX® STAINLESS STEEL TUBING (CSST) (PATENTED SYSTEM)

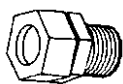
Corrugated Stainless Steel Tubing Conveys Gas. Material Tubing 304 Stainless Steel with Yellow Polyethylene Jacketing (International Color Code for Gas). All hoses clearly marked with gas pressure rating, EHD (Equivalent Hydraulic Diameter) and the words "Fuel Gas".



PFCT-3875	3/8"	(10mm)
PFCT-1275	1/2"	(15mm)
PFCT-3475	3/4"	(20mm)
PFCT-0175	1"	(25mm)
PFCT-0114	1 1/4"	(31mm)



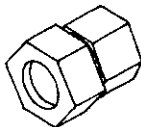
**NOTE: 225 & 150 FT. COILS ARE ON DISPOSABLE SPOOLS.**



#### BRASS MECHANICAL MALE FITTING

Includes: Retainer Ring, Slide Ring, Silicone O-Ring and High Temperature Sealing Gasket

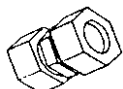
PFMF-3805	3/8" (10mm) with 1/2" NPT
PFMF-3812	3/8" (10mm)
PFMF-1212	1/2" (15mm) tapped to 3/8" female
PFMF-3406	3/4" (20mm) tapped to 1/2" female
PFMF-0106	1" (25mm) tapped to 3/4" female
PFMF-0114	1 1/4" (31mm) tapped to 1" female



#### BRASS MECHANICAL FEMALE FITTING

Includes: Retainer Ring, Slide Ring, Silicone O-Ring and High Temperature Sealing Gasket

PFFN-3812	3/8" (10mm)
PFFN-1212	1/2" (15mm)
PFFN-3406	3/4" (20mm)
PFFN-0106	1" (25mm)

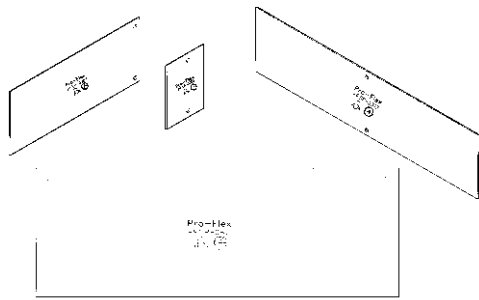


#### BRASS UNION

Includes: Retainer Ring, Slide Ring, Silicone O-Ring and High Temperature Sealing Gasket

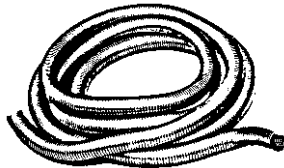
PFUF-3812	3/8" (10mm)
PFUF-1212	1/2" (15mm)
PFUF-3406	3/4" (20mm)
PFUF-0106	1" (25mm)

**STRIKER PLATES**



PFSP-0312	3 x 12
PFSP-0307	3 x 7
PFSP-0302	3 x 2
PFSP-0617	6 x 17

**FLOPPY-FLEX™ PROTECTIVE ARMOR**



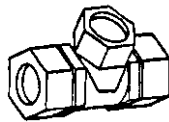
PFFF-3450	3/4" fits 3/8" (10mm)	50 ft. per coil
PFFF-0150	1" fits 1/2" (15mm)	50 ft. per coil
PFFF-1225	1-1/4" fits 3/4" (20mm)	25 ft. per coil
PFFF-1525	1-1/2" fits 1" (25mm)	25 ft. per coil

**1 FOOT LONG, FLOPPY-FLEX™ GALVANIZED PROTECTIVE CONDUIT**



PFFF-3412	3/4" fits 3/8" (10mm)	50 pcs. per box
PFFF-0112	1" fits 1/2" (15mm)	50 pcs. per box
PFFF-1212	1-1/4" fits 3/4" (20mm)	25 pcs. per box
PFFF-1512	1-1/2" fits 1" (25mm)	25 pcs. per box

**RUN RUN BRANCH  
BRASS TEE 1/2" X 1/2" X 1/2"**



**BRASS TEES - Pro-Flex® Fitting**

PFTE-BBB6	1/2" x 1/2" x 1/2"
PFTE-CCB6	3/4" x 3/4" x 1/2"
PFTE-DCB6	1" x 1" x 1/2"
PFTE-CBB6	3/4" x 1/2" x 1/2"
PFTE-CCC6	3/4" x 3/4" x 3/4"

**BRASS TEES - Female Branch PFTF**

PFTF-BBB6	1/2" x 1/2" 1/2"
PFTF-CCB6	3/4" x 3/4" x 3/4"
PFTF-DCB6	1" x 1" x 1/2"
PFTF-CBB6	3/4" x 1/2" x 1/2"
PFTF-CCC6	3/4" x 3/4" x 3/4"

**ACCESSORY PARTS-PACKAGED**

Includes: 4 only Retainer Rings  
2 only Slide Rings  
2 only Silicone O-Rings  
2 only High Temperature Sealing Gaskets

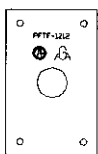
PFAP-3810	3/8" Dia	(10mm)
PFAP-1210	1/2" Dia	(15mm)
PFAP-3410	3/4" Dia	(20mm)
PFAP-1010	1" Dia	(25mm)
PFAP-0114	1 1/4" Dia	(31mm)



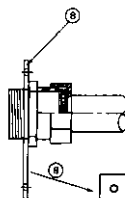
**NEW... SPECIAL TERMINATION PLATE  
WITH FITTING ATTACHED  
(Patent #6,488,316)**

PFST-12	1/2" Dia (15mm)
PFST-34	3/4" Dia (20mm)

**THREADED TERMINATION PLATES**



PFTP-3812	3/8"
PFTP-1212	1/2"
PFTP-3412	3/4"
PFTP-0112	1"
PFTP-0114	1 1/4"



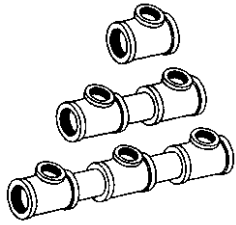
**TERMINATION BRACKET**

Termination BRACKET -Terminate Gas Piping at Gas Equipment

**THREADED TERMINATION PLATE:**

PFTP-3812	3/8"	(Note: When using Termination Plate on outdoor applications, coat Termination Plate with an outdoor protective paint)
PFTP-1212	1/2"	
PFTP-3412	3/4"	
PFTP-0112	1"	
PFTP-0114	1 1/4"	

**ADDITIONAL ITEMS APPROVED AS PART OF THE PRO-FLEX® CSST FLEXIBLE GAS SYSTEM**

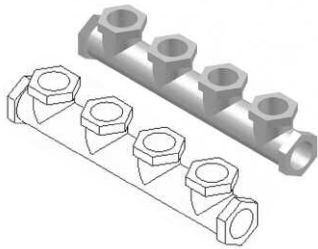


**MULTIPOINT GAS DISTRIBUTING MANIFOLDS**

Manifolds supply multiple gas appliances in parallel arrangement from main distributing point. Single Tee and Multiple Tee Manifold Assemblies.

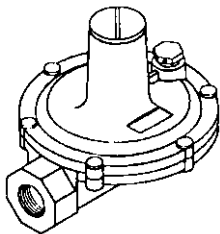
Single Tee and Multiple Tee Manifold Assembly  
(Standard 150 lb Malleable Iron Threaded Fittings)

**- OR -**



**CAST MANIFOLDS**

PFMM-CCB6      3/4" x (4) 1/2" x 3/4"  
PFMM-BBB6      1/2" x (4) 1/2" x 1/2"



**REGULATORS**

Maxitrol 325.3, (PFMR-3253) and 325-5A, (PFMR-3255) for Dual Pressure Systems.

Specifications:	Maxitrol 325 Series or Equal
Maximum Inlet Pressure:	10 PSIG
Emergency Exposure Limits:	65 PSIG
Ambient Temperature Limits:	-40° to 250° F
Venting:	325.3 Model 1/8" NPT 325.5A Model 1/4" NPG

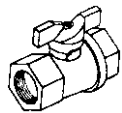
Model 325-5  
Port Size: 3/4" x 3/4" MPT  
Vent Size: 3/8" MPT

Model 325-3  
Port Size: 1/2" x 1/2" MPT  
Vent Size: 1/8" MPT



**BONDING CLAMP**

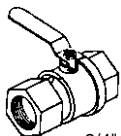
PFBC-AB      Bronze UL listed 467 Bonding Clamp used with 3/8" and 1/2"  
PFBC-CDE      Bronze UL listed 467 Bonding Clamp used with 3/4", 1" and 1 1/4"



1/2" x 1/2" MPT

**BALL VALVES**

Ball Valves or (Shut Off Valves) that comply with ANSI/ASME B16.44-2002 manually operated metallic gas valves for use in above ground piping systems up to 5psi. Valves must be used with the following requirements: a) Gas appliances must have an accessible 1/2 PSIG manual shut-off valve upstream of connectors and a union to allow removal of appliance, b) An accessible manual gas shut-off valve is required upstream of each pressure regulator on elevated pressure systems. You may use T100 valves on the elevated pressure side of CSST installations. Standard approved gas shut off valves may be used on low pressure (Appliance) side of installations.



3/4" x 3/4" MPT

1/2" x 1/2" MPT  
3/4" x 3/4" MPT  
3/8" x 3/8" MPT

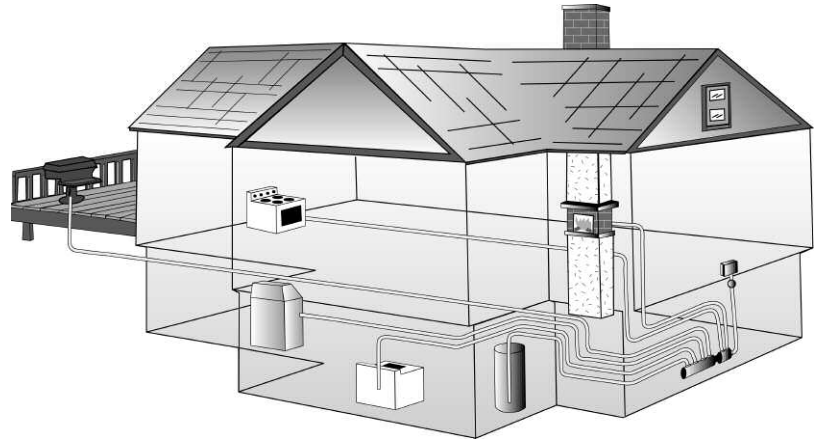
**TOOLS NEEDED FOR ASSEMBLY OF PRO-FLEX® CSST**

- STANDARD TUBE CUTTER
- UTILITY KNIFE
- CRESCENT WRENCH

# 3.0 System Configuration

## Configuration

Prior to piping installation, refer to building plans or prepare a sketch showing the location of the appliances, the various appliance load demands, point of delivery (location of gas meter or second stage LP regulator), and possible piping routes. Appliance load demand data can be obtained from the manufacturers name-plate located on each appliance, or provided to the system designer by the builder/contractor.



- a) Determine the local piping restrictions prior to installing the flexible gas piping. Confirm that the local administrative authority has accepted the use of flexible gas piping. Corrugated Stainless Steel Tubing has been accepted by most major code bodies, but local or state adoption of these codes often lags behind. Check with the local administrative authority.

- b) Determine metered (supply) pressure.

Natural Gas:

- Standard low-pressure supply throughout the USA and Canada is usually 6-7 inches water column (also designated as 1/4 PSI or 4 ounces).
- Higher pressure supply such as 14 inches w.c. (1/2 PSI) and 2 PSI provide significant CSST size reduction. Check with the local gas utility for the availability of elevated pressure.

Propane (Liquefied Petroleum Gas):

- LP is typically supplied within residential buildings at 11 inches w.c. This pressure is set at the second stage regulator.
- Elevated pressure settings from 14 inches w.c. to 2 PSI and 5 PSI also provide CSST size reductions. Check with the propane gas supplier for available pressure.

- c) Determine the total capacity needed for all appliances. CFH/BTUH equivalents for natural gas or propane flow can be obtained from the local gas utility or propane supplier. The capacity tables within this guide or any approved CSST tables should be used to determine pipe sizing needed to meet BTUH input load requirements.

- For natural gas with a specific gravity of 0.60, one cubic foot per hour (1 CFH) is approximately 1,000 BTUH.
- For propane gas with a specific gravity 1.52, one cubic foot per hour (1 CFH) is approximately 2,500 BTUH.

# Series and Parallel (Low Pressure) System

## DETERMINE TOTAL CAPACITY NEEDED FOR APPLIANCES.

Data can be obtained from the manufacturers nameplate located on the gas appliance. BTU equivalents for CFH can be obtained from the local utility. In most cases, one Cubic Foot per Hour (1 CFH) is estimated to be 1,000 BTUH heating value (natural gas) and Propane has a heating value around 2,500 BTUH, making the capacity tables easy to utilize with appliance BTU input loads.

## DETERMINE THE TYPE OF PIPING LAYOUT WHICH BEST FITS THE INSTALLATION

### SERIES SYSTEMS

A series layout is the most common arrangement utilized for rigid pipe systems for low pressure. These usually consist of a main run (header) with tees branching off to each appliance. In a traditional series system, the service pressure down stream of the meter is typically less than 1/2 PSI.

The minimum pressure supplied to any given appliance is an important consideration. To operate properly, most **Natural Gas appliances require a minimum of 4"WC pressure** and most **Propane (Liquefied Petroleum) appliances require a minimum of 10"WC pressure**. Allowable pressure drop along any particular run may be dictated by local code restrictions.

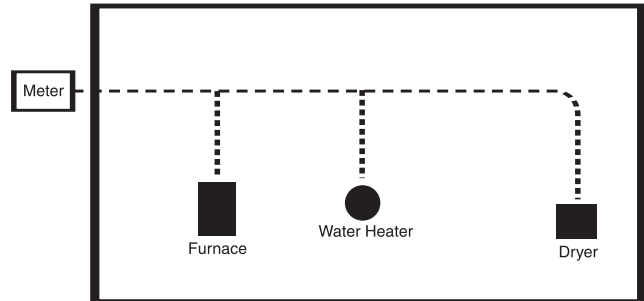
### PARALLEL SYSTEMS

In a parallel system, appliances are serviced by individual runs that stem off from a central distribution manifold. A main run from the meter supplies the manifold. The manifold station is located close to the greatest load, typically the boiler or furnace. A parallel layout is most likely to be used in 1/4 to 1/2 psi systems.

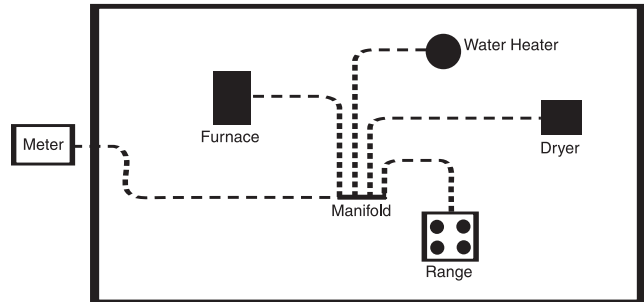
### DUAL PRESSURE SYSTEM

A dual pressure system incorporates two operating pressures downstream from the meter. The first pressure, set by the service regulator at the meter, is usually 2 psi, but can be higher or lower depending on code restrictions and gas company policy. This part of the system is sized separately and ends at the pounds-to-inches regulator inlet. The allowable pressure loss for this part of the system must be added to the effect of the regulator to determine the available pressure at the regulator outlet. See chart page 35, Regulator Capacity Table.

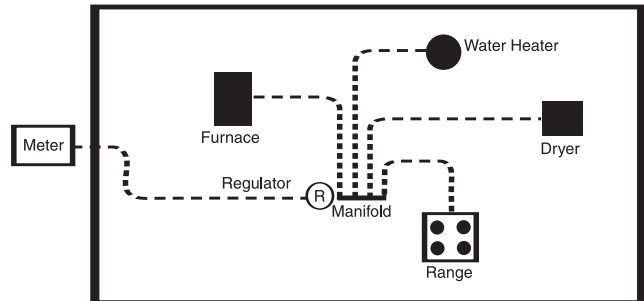
The second pressure, at the outlet of the pounds-to-inches regulator is under 1/2 PSI, usually 8"WC for natural gas and 11"WC for propane. Generally, a parallel system requires a higher total footage of smaller diameter tubing and fewer fittings compared to a series layout.



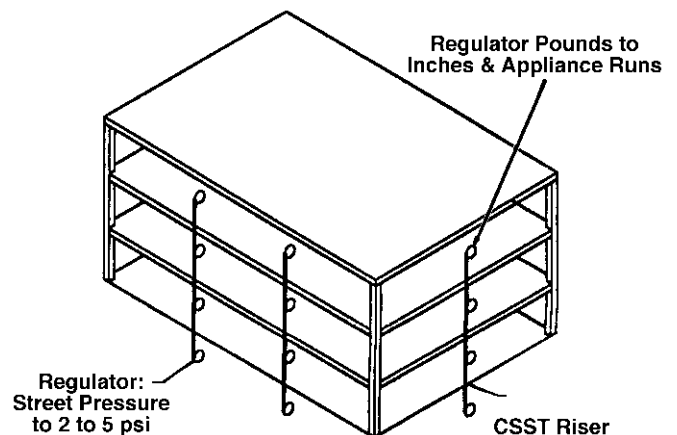
**SERIES**



**PARALLEL**



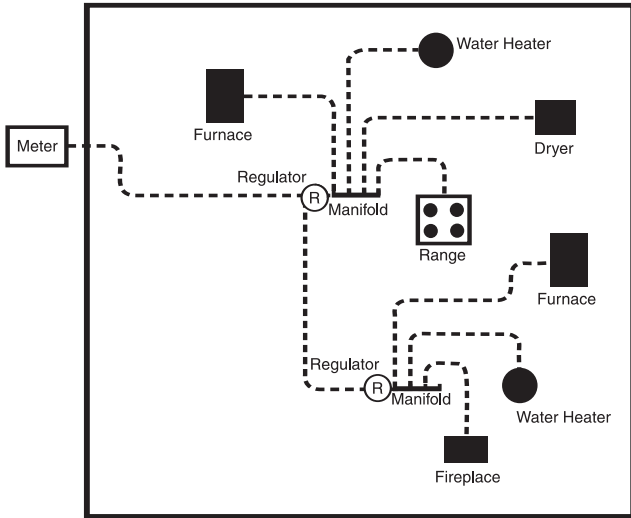
**DUAL PRESSURE SYSTEM**



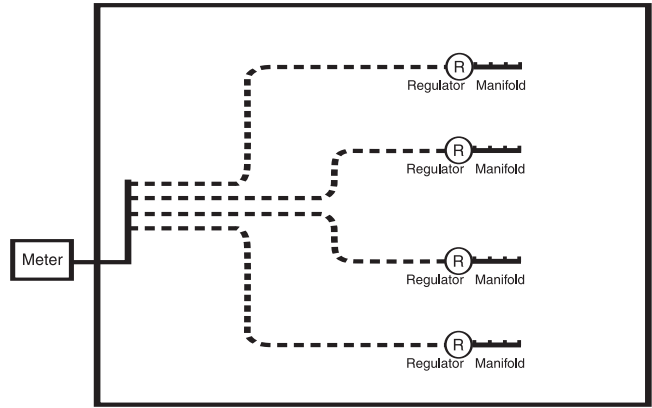
**MULTI-UNIT APARTMENT BUILDING**

# MULTIPLE MANIFOLD SYSTEM

For those installations in which the energy load demand is large or the appliances are installed throughout the structure with long distances from the meter, a multiple manifold system may be used. Elevated pressure systems are a safe, efficient method of providing for larger BTU load demands while maintaining smaller pipe diameters.

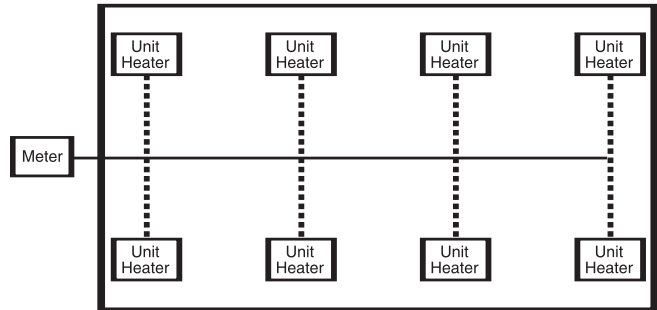


**MULTIPLE MANIFOLD SYSTEM**



## COMBINATION STEEL/CSST SYSTEM (Hybrid)

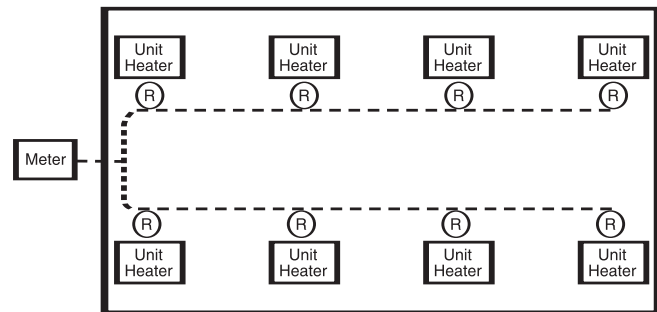
In a hybrid system, corrugated stainless steel tubing is used in combination with rigid pipe or copper tubing. In lower pressure systems it is often advantageous to use both CSST and rigid pipe to help minimize pressure drops typically encountered on systems with high loads and/or long runs. **Pro-Flex® Flexible Gas Piping is approved for use in combination with all approved fuel gas-piping materials by using approved pipe threads at the interface.**



**HYBRID SYSTEM**

## ELEVATED PRESSURE SYSTEM

In a complete elevated pressure system, corrugated stainless steel tubing is used to deliver pressures in excess of 1/2 psi to a pounds-to-inches regulator positioned directly in front of each appliance regulator. This is an alternate method of installation used to minimize pressure drops typically encountered on systems with high loads and/or long runs.



**ELEVATED PRESSURE SYSTEM**

**ALLOWABLE PRESSURE DROP:**

The **Pro-Flex®** gas piping system is required to be “tested, listed and installed in accordance with the ANSI standard for fuel gas piping systems using corrugated stainless steel tubing, ANSI LC-1-2005. This standard, among other things, requires the manufacturer to provide installation instructions including the necessary pipe sizing tables and methods.

With respect to gas piping sizing, the intent of all model codes is to ensure there is sufficient gas volume and gas pressure supplied to the appliance for proper operation. Language from the International Fuel Gas Code clearly illustrates this point.

**“Allowable pressure drop** The design pressure loss on any piping system under maximum probable flow conditions, from point of delivery to the inlet connection of the equipment, shall be such that the supply pressure at the equipment is greater than the minimum pressure required for proper equipment operation.”

Natural gas appliances are typically designed to operate with a minimum inlet pressure of 4.0 inches water column. Propane appliances are typically designed to operate with a minimum inlet pressure of 10.0 inches water column.

The natural gas capacity tables published by Tru-Flex Metal Hose Corp. (Pro-Flex® CSST), should be used to provide for no less than 5” water column pressure to the appliance inlet. The propane capacity tables should be used to provide no less than 10.5” water column pressure to the appliance inlet.

This can be done by subtracting the desired appliance inlet pressure (5” WC for NG, 10.5” WC for LPG) from the gas source pressure (gas meter for NG, secondary regulator for LPG) to get allowable pressure drop. Use the Pro-Flex® capacity table labeled with the appropriate allowable pressure drop and gas type. This will result in an additional pressure drop capacity over the commonly used 1/2” WC drop associated with the Longest Run Method.

Reference Data for Proper System Sizing:

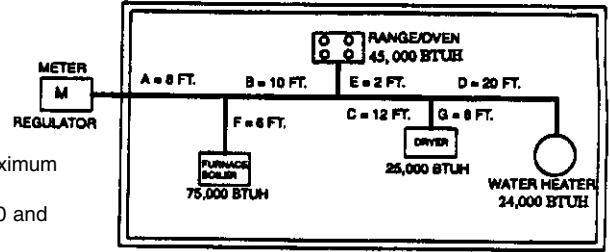
PRESSURE CONVERSION FACTORS	FUEL GAS INFORMATION		
1/4 psi = 6.921 in w.c. = (approx. 7” WC)	Natural Gas Propane		
1/2 psi = 13.842 in w.c. = (approx. 14” WC)	BTU per Cubic Foot =	1000	2516
1 psi = 27.684 in w.c. = (approx. 28” WC)	Specified Gravity =	0.60	1.52
2 psi = 55.368 in w.c. = (approx. 56” WC)	Note: to determine the CFH of Natural Gas, divide by BTU load by 1000. To determine the CFH of Propane, divide the BTU by 2516		
5 psi = 138.42 in w.c. = (approx. 140” WC)			

# 3.2 Sizing Methods and Examples

## SIZING PROCEDURES PRO-FLEX® CSST, FLEXIBLE GAS TUBING

### LONGEST LENGTH METHOD EXAMPLE #1

This is a low-pressure series system with four natural gas appliances. The utility company supply pressure exiting the meter is 6 inches water column, and the maximum allowable pressure drop across the longest length from the meter to the farthest appliance is 1/2 inch water column. The gas supplied has a specified gravity of .60 and an energy content of 1 cubic foot per hour equals 1,000 BTU per hour.



Low Pressure (5" to 7" WC) Natural Gas (Series System)

APPLIANCE LOADS	+GAS LOAD	LENGTH OF RUN
FURNACE	75 CFH (75,000 BTUH/1000 PER CFH)	14 FEET
OVEN/RANGE	45 CFH (45,000 BTUH/1000 PER CFH)	20 FEET
DRYER	25 CFH (25,000 BTUH/1000 PER CFH)	38 FEET
WATER HEATER	24 CFH (24,000 BTUH/1000 PER CFH)	50 FEET

TOTAL.....169 CFH

### LENGTH OF EACH RUN

A = 8 FEET	<b>EXAMPLE:</b>
B = 10 FEET	Furnace: A (8 ft) + F (6 ft) = <u>14 FEET</u>
C = 12 FEET	Oven/Range: A (8 ft) + B (10 ft) + E (2 ft) = <u>20 FEET</u>
D = 20 FEET	Dryer: A (8 ft) + B (10 ft) + C (12 ft) + G (8 ft) = <u>38 FEET</u>
E = 2 FEET	Water Heater: A (8 ft) + B (10 ft) + C (12 ft) + D (20 ft) = <u>50 FEET</u>
F = 6 FEET	<b>THE LONGEST RUN IS FROM THE METER TO THE WATER HEATER; OVER 50 FEET.</b>
G = 8 FEET	

### SIZING SECTION A:

Length A must be sized to handle the total load of all appliances and the total pressure drop from the meter to the farthest appliance. The total appliance load is 169 CFH. Using the longest length sizing method, the length is 50 ft. to the water heater. Referring to Table 1, (6" WC inlet pressure and 1/2" WC pressure drop) under the 50 ft. length column, we find that 1 inch size has the flow capacity exceeding 169 CFH (171 CFH). Use 1" tubing to run Section A.

### SIZING SECTION B:

Section B must supply the water heater, dryer and range. The total pressure drop for the system is considered to be from the meter to the water heater (farthest appliance). The total appliance load is 24+25+45 = 94 CFH. Using the longest length sizing method, the length is 50 ft. (distance from meter to water heater). Referring to Table 1 under the 50 ft. length column, we find that size 1 inch has flow capacity over 94 CFH (171 CFH). Use 1" tubing to run Section B.

### SIZING SECTION C:

Section C must supply the water heater and dryer. The total appliance load is 24+25 = 49 CFH. Using the longest length method, the length is 50 ft. Referring to Table 1 under the 50 ft. length column, we find that 3/4 inch has flow capacity above the 49 CFH (89 CFH) Use 3/4" tubing to run Section C.

### SIZING SECTION D:

Section D must supply the water heater. The total appliance load is 24 CFH. Using the longest method, the length is 50 ft. Referring to Table 1 under the 50 ft. length column, we find that 1/2 inch has flow capacity above 24 CFH (32 CFH). Use 1/2" tubing to run Section D.

### SIZING SECTION E:

The total appliance load is 45 CFH. Using the longest length method, the length is 50 ft. Referring to Table 1 under 50 ft. length column, we find that 3/4" has flow capacity above 45 CFH (89 CFH) Use 3/4" tubing to run Section E.

### SIZING SECTION F:

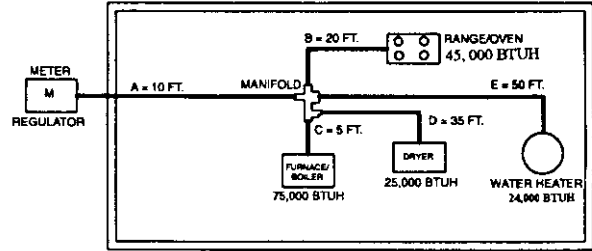
The total appliance load is 75 CFH. Using the longest length method, the length is 50 ft. Referring to Table 1 under 50 ft. length column, we find that 3/4" has flow capacity above 75 CFH (89 CFH) Use 3/4" tubing to run Section F.

### SIZING SECTION G:

The total appliance load is 25 CFH. Using the longest length method, the length is 50 ft. Referring to Table 1 under 50 ft. length column, we find that 1/2" has flow capacity above 25 CFH (32 CFH) Use 1/2" tubing to run Section G.

## EXAMPLE #2, MEDIUM PRESSURE PARALLEL SYSTEM

This is a medium-pressure parallel system which includes a distribution tee manifold. The natural gas supply pressure is 1/2 psig and the maximum allowable pressure drop from the meter to the farthest appliance is 6" WC.



Medium Pressure (1/2 psig) Natural Gas (Parallel System)

Appliance Loads	Lengths	size
Oven/Range 45 CFH	A = 10 FT	3/4"
Furnace = 75 CFH	B = 20 FT	3/8"
Dryer = 25 CFH	C = 5 FT	3/8"
Water Heater = 24CFH	D = 35 FT	3/8"
	E = 50 FT	3/8"
TOTAL CFH.... 169 CFH		

### SIZING, SECTION A:

Determine distance from the meter to the farthest appliance (water heater 60 ft.) Determine the total appliance load supply by Section A (169 CFH). Referring to Table 4 under the 60 ft. length column, we find 3/4 inch has flow capacity above 169 CFH (274 CFH). Use 3/4" tubing to run Section A.

### SIZING SECTION B:

Section B supplies the oven/range. The total pressure drop is considered from the meter to the oven/range. The total appliance load is 45 CFH and the length is 10 ft + 20 ft. = 30 feet total. Referring to Table 4 under the 30 ft. length column, we find that 3/8 inch has a flow capacity above 45 CFH (94 CFH). Use 3/8" tubing to run Section B.

### SIZING SECTION C:

Section C supplies the furnace. The total appliance load is 75 CFH and the total length is 10 ft. + 5 ft. = 15 ft total. Referring to Table 4 under the 15 ft. length column. We find that 3/8 inch has a flow capacity above 75 CFH (134 CFH) Use 3/8" tubing to run Section C.

### SIZING SECTION D:

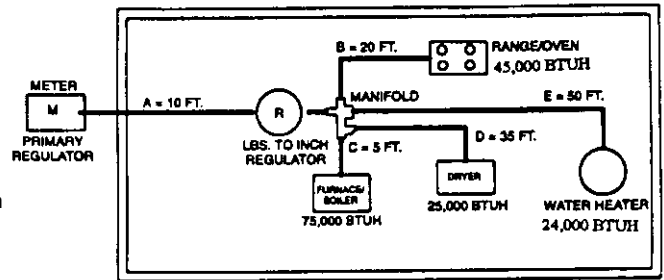
Section D supplies the dryer. The total appliance load is 25 CFH and the total length from the meter is 10 ft. + 35 ft. = 45 feet total. Referring to Table 4 under the 45 ft. length column. Since 45 ft. does not appear in the table, use the next longest run column of 50 ft. We find that 3/8 inch has a flow capacity above 25 CFH (73 CFH) Use 3/8" tubing to run Section D.

### SIZING SECTION E:

Section E supplies the water heater. The total appliance load is 24 CFH and the total length from the meter to appliance is 10 ft + 50 ft = 60 feet total. Referring to Table 4 under the 60 ft. length column, we find that 3/8 inch has a flow capacity above 24 CFH (65 CFH) Use 3/8" tubing to run Section E.

### EXAMPLE #3 - ELEVATED DUAL PRESSURE SYSTEM

This is a 2 psig supply pressure parallel arrangement. The natural gas system incorporates a pressure reducing regulator with a distribution tee manifold located closely to several large capacity appliances. The inlet pressure downstream of the meter is 2 psig, and the designated maximum pressure drop from the meter to the reducing regulator is 1.0 psig. The outlet pressure from the regulator is set at 8 inches water column. A 3" WC pressure drop is used in sizing the tubing from the regulator outlet to each appliance. Specified gravity of the gas delivered is .60 and energy content is 1 CFH 1,000 BTUH.



Elevated (2 psig) Dual Pressure Natural Gas (Parallel System)

#### Total load and regulator size:

Calculate the total appliance load and determine if one regulator has sufficient capacity to supply this load. One regulator is normally adequate when appliances are close together. When groups of high-load appliances are widely separated, it is often more economical to use one pressure reducing regulator to supply each appliance group. The total appliance load required is 169 CFH (169,000 BTUH). The supply pressure from the meter is 2 psig and the designated pressure drop from the meter to the regulator is 1 psig; thus the

APPLIANCE LOADS	LENGTHS	TUBE SIZE
METER TO REGULATOR	A= 10 FEET	3/8"
OVEN/RANGE = 45 CFH	B = 20 FEET	3/8"
FURNACE = 75 CFH	C = 5 FEET	3/8"
DRYER = 25 CFH	D = 35 FEET	3/8"
WATER HEATER=24 CFH	E = 50 FEET	3/8"
TOTAL.....	169 CFH	

minimum inlet pressure to the regulator is 1 psig. Since the outlet pressure of the regulator is set at 8" WC, the expected pressure drop across the regulator is 20 inches WC (1 psig - 8" WC = 20" WC). A single 325-3 regulator has a flow rate capacity of 252 CFH. This capacity exceeds the system requirement of 169 CFH. In cases where the 325-3 regulator capacity is insufficient, a larger #325-5A regulator or parallel arrangement of two regulators should be used.

#### SIZING SECTION A (METER TO REGULATOR):

Section A must be sized to handle all appliances loads and supply the pressure reducing (pounds to inches) regulator. The total load is 169 CFH and the length is 10 ft. The supply pressure is 2 psig and the pressure drop is 1 psig. Referring to Table 5 (meter to regulator with 2 psig inlet and 1 psig drop) under the 10 ft. column, we find that 3/8 inch has capacity over 169 CFH (332 CFH). Use 3/8" tubing to run Section A. To size the other sections, the pressure source is the outlet of the pressure regulator rather than the meter. Use the low-pressure Table 3 (8.0" WC inlet with 3.0" WC drop) and size each section individually using the appliance load and run distance.

#### SIZING SECTION B

Section B supplies the oven/range. The load is 45 CFH and the distance between the regulator outlet and appliance is 20 ft. The total pressure drop is from the outlet of the reducing regulator to the oven/range. The outlet pressure from the regulator is 8" WC and the pressure drop is 3" WC. Referring to Table 3, under the 20 ft. length column, we find that an 8 inch has a flow capacity above 45 CFH (81 CFH). Use 3/8" tubing to run Section B.

#### SIZING SECTION C:

Section C supplies the furnace. The load is 75 CFH and the distance is 5 ft. Referring to Table 3, under the 5 ft. length column, we find that 3/8 inch has a flow capacity above 75 CFH (162 CFH). Use 3/8" tubing to run Section C.

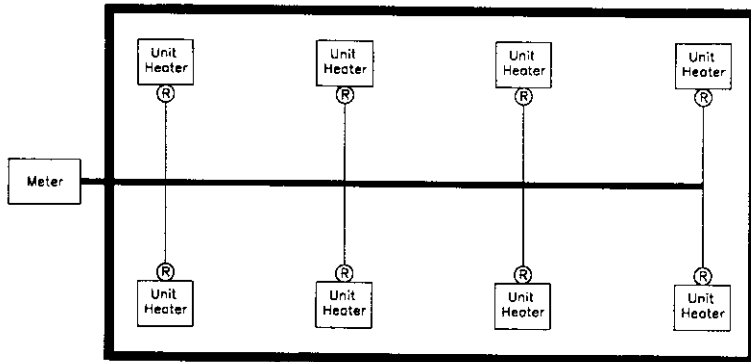
#### SIZING SECTION D:

Section D supplies the dryer. The load is 25 CFH and the distance is 35 ft. Referring to Table 3, and since a 35 ft. length column does not exist, use the 40 ft. length column. We find that 3/8 inch has a flow capacity above 25 CFH (58 CFH). Use 3/8" tubing to run Section D.

#### SIZING SECTION E:

Section E supplies the water heater. The load is 24 CFH and the distance is 50 ft. Referring to Table 3, under the 50 ft. length column, we find that 3/8 inch has a flow capacity above 24 CFH (51 CFH). Use 3/8" tubing to run Section E.

## COMBINATION STEEL/ CSST (Hybrid System)



(Hybrid system)

Is Corrugated Stainless Steel Tubing used in combination with Rigid Pipe or Copper Tubing. In a low and medium pressure system it is often to your advantage to use both CSST and rigid pipe to help minimize pressure

drops typically encountered on systems with high loads and/or long runs. **PRO-FLEX® CSST** is approved for use in combinations with approved gas piping materials by using approved pipe threads at the interface. For sizing use longest run method assuming the complete run is CSST.

# 4.0 Installation/Practices Guidelines

- Pro-Flex**® flexible gas piping (CSST) may only be installed by a Qualified/Trained Installer who has been trained in the use of **Pro-Flex**®. A Qualified/Trained Installer card is required to purchase and install **Pro-Flex**® (CSST) Flexible Gas Piping.
- Only the components provided or specified by Tru-Flex Metal Hose Corp., (including Pro-Flex's striker plates and Floppy Flex™ armor conduit) as part of the piping system are to be used in the installation.
- Never use **Pro-Flex**® flexible gas piping or system components as a ground electrode or as a grounding path for appliances or electrical systems.
- Pro-Flex**® (CSST) flexible gas piping routed in a location which is concealed, constrained and within 3 inches of a potential threat will be protected against damage by protection devices listed in the **Pro-Flex**® Installation/Training Guide. Contact with sharp objects or harmful substances should be avoided.
- Concealed tubing shall be protected from puncture threats, using the striker plates provided, at all points of penetration through studs, joists, plates or similar structures. The extend of protection is defined as follows:
  - All points of penetration less than 2 inches (50.8mm) from any edge of a stud, joist, plate etc., a striker plate is required to provide protection at the area of support and within 5 inches (127mm) of each side (if appropriate) of the support.
  - At points of penetration 2 to 3 inches (50.8 to 76.2mm) from any edge of a stud, joist, plate, etc., a striker plate is required to provide protection throughout the area of support.
  - At points of penetration greater than 3 inches (76.2mm) from any edge of a stud, joist, plate etc., no protection is required.
  - Tubing routed horizontally through studs shall be protected from puncture threats between the studs using shielding devices provided.

- CSST greater than 1-in (25.4 mm) inside diameter installed within hollow cavity walls of 2 x 4 construction shall be protected along the entire concealed length in the manner and using the shielding devices specified by the manufacturer.
- The width of the installed striker plate, at the points of penetration through wall studs, floor joists, plates, sills, etc., shall be out at least 1.5 times the outside diameter of the tubing.

- Open ends of the tubing are to be temporarily plugged or taped closed prior to installation to prevent entrance of dirt, dust or other debris.
- The protective yellow jacketing should be kept in place as much as possible to protect the tubing from corrosive threats. Contact with chemicals containing chlorides must be followed by thorough rinse and wipe dry. This includes fluxes used to solder copper tubing and acid base cleaners used to wash masonry.

Recommended Installation for Clearance Holes for Routing CSST.	
Tubing Size	Drill Hole Size
3/8" (10mm)	1-1/8"
1/2" (15mm)	1-3/8"
3/4" (20mm)	1-1/2"
1" (25mm)	1 -3/4"
1 1/4" (31mm)	2 -1/4"

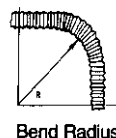
- Installation clearance holes for routing CSST are to be approximately 1/2 inch greater than the O.D. of the CSST. Drilling of any structural member must be in conformance with the local building codes. Refer to the table for the recommended drill hole sizing.

- Supporting CSST. Tubing shall be supported with pipe straps, bands or hangers suitable for the size and weight of the tubing, at intervals not to exceed those shown in the table. Tru-Flex® Metal Hose Corp., recommends the use of metal pipe straps because some plastic clips are susceptible to breakage upon subsequent handling. When supporting CSST tubing runs the use of other conductive metallic systems such as metallic appliance vents, metallic ducting and piping, and electrical cables must be avoided.

Recommended Horizontal and Vertical Support Spacing for PRO-FLEX CSST		
CSST Pipe Size	Horizontal Support Spacing	Vertical Support Spacing
3/8" (10mm)	4 ft.	10 ft
1/2" (15mm)	6 ft.	10 ft
3/4" (20mm)	8 ft. (USA) 6 ft. (CANADA)	10 ft
1" (25mm)	8 ft. (USA) 6 ft. (CANADA)	10 ft
1 1/4" (31mm)	8 ft. (USA) 6 ft. (CANADA)	10 ft

- Recommended MINIMUM BEND RADIUS FOR CSST:

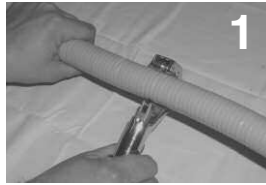
Recommended Minimum Bend Radius for PRO-FLEX® CSST		
CSST Pipe Size	Absolute Min. Bend Radius	Recommended Min. Bend Radius
3/8" (10mm)	9/16 inch	3 inches
1/2" (15mm)	3/4 inch	3 inches
3/4" (20mm)	1.0 inch	3 inches
1" (25mm)	3.0 inches	5 inches
1 1/4" (31mm)	3.0 inches	5 inches



13. Undue stress or strain on the tubing and fittings should be avoided. Also avoid sharp bends, stretching, kinking or twisting of the CSST tubing.
14. Sizing of **Pro-Flex**<sup>®</sup> CSST must be performed using the capacity tables found in this **Pro-Flex**<sup>®</sup> Installation/Training Guide.
15. **Pro-Flex**<sup>®</sup> (CSST) flexible gas piping should not be connected to moveable appliances. Connections to moveable appliances such as ranges and clothes dryers should be accomplished with a “flexible gas appliance connector.”
16. Regulators are suitable for multi-poise mounting. When using a vent limiting device, the regulator must be mounted in a horizontal upright position. For outdoor venting, the vent line must be at least the same size as the vent connection and no longer than 30 feet before upsizing. When mounting a regulator outdoors, remove vent limiting device and position regulator inverted with open port down.
17. A manifold assembly utilizing a pounds-to-inches regulator shall include a shut-off valve ahead of the regulator and installed in an accessible location so that the regulator can be inspected, maintained and serviced if necessary.
18. Buried or Embedded: CSST shall not be buried directly in the ground or directly embedded in concrete (i.e.: patio slabs, foundations and walkways) When it is necessary to bury or embed CSST, the tubing shall be routed inside a non-metallic, watertight conduit that has an inside diameter at least 1/2 inch greater than the O.D. of the CSST Tubing For ends of conduit installed outdoors, the conduit shall be sealed at any exposed end to prevent water from entering. No mechanical joint fittings are permitted within the conduit. *Note: CSST must be buried in accordance with all local building codes.*
19. **Pro-Flex**<sup>®</sup> (CSST) flexible gas piping system must be pressure tested for leaks during rough construction in accordance with all local codes. In the absence of local requirements, test in accordance with Part 4 of the NFPA 54, National Fuel Gas Code ANSI Z223.1 and/or CSA B149.1 Installation Codes or in accordance with the requirements of the applicable local codes. For a ‘one-part’ pressure-test, the regulator should be removed from the system. For a ‘two-part’ test, the regulator should be isolated from downstream test pressures.
20. Along Side of a structure: When installed along the outside of a structure (between the ground and height of 6 ft) in an exposed condition, the CSST shall be protected from mechanical damage inside a conduit or chase. A conduit or chase is not required if the tubing is installed in a location that will not subject the CSST to mechanical damage.
21. Meter Hook-Ups. Refer to the **Pro-Flex**<sup>®</sup> installations and illustrations shown in this training guide. CSST shall not be used as a means of support for the gas meter. Also check with your local code official or authority having jurisdiction on meter hook-ups. Some restrictions may apply. Local code requirements will always take precedence.
22. For a Piping system which includes manual gas valves listed as complying with ASME B16.44-2002. Manually operated metallic gas valves for use in above ground piping systems up to 5 psi.
23. When using **Pro-Flex**<sup>®</sup> Flexible Gas Piping (CSST) then Metal Enclosures the CSST tubing must be protected by grommets, bushing or armor (Floppy-Flex™), PVC tape, shrink sleeve material or a minimum of four (4) wraps of #10 Mil Duct-Tape. This is to ensure that no physical contact will be made between the metal and the CSST tubing that would cause mechanical wear.
24. In accordance with the NFPA 54 Section 7.13, Tru-Flex Metal Hose Corp., requires proper bonding of the Pro-Flex<sup>®</sup> gas-piping systems in a structure to the structure’s electrical grounding system. This must be performed by a qualified person recognized by the local jurisdiction as capable of performing such work. These requirements are for all Pro-Flex<sup>®</sup> CSST installations.

# 4.2 Fitting Assembly

## ASSEMBLY PROCEDURES FOR PRO-FLEX® CSST



### STEP #1

#### Cut-to-Length

Using a standard tube cutter, cut tubing to the desired length leaving approximately one inch for fitting attachment. Clean up any jagged edges burrs.



### STEP #2

#### Strip Yellow Jacket

Using a utility knife, strip yellow jacket back 5-6 convolutions from the tubing end. Note: Do not use tube cutter to make yellow jacket cut, use utility knife.



### STEP #3

#### Assembly of Mechanical Fitting

Slide nut over CSST tubing with threaded end pointing out.



### STEP #4

#### Placement of Retainer Ring

By hand, open ring wide enough to fit in the valley behind the fourth (4th) convolution and hand squeeze ring to close and fit snug. Do not break the retainer ring in half.



### STEP #5

#### Placement of Stainless Steel Slider Ring

Place Slider Ring over the tube end and roll/slide it down to the retainer ring.



### STEP #6

#### Placement of Silicone O-Ring

Roll Silicone O-Ring over tube end and roll/slide it down to meet the slider ring.



### STEP #7

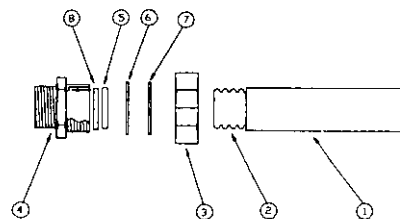
#### Make sure High-Temperature Sealing Gasket is in base of Fitting

Double check to make sure High-Temperature Sealing Gasket is in base of Fitting and hand-tighten down fitting to nut. NOTE: Before tightening down, check to make sure Retainer Ring, Slider Ring, and Silicone O-Ring are in the proper sequence. After hand tightening fitting to nut, give it one additional 1/4 to 1/2 turn with a crescent wrench. During tightening rotate the nut only, the body should not rotate with respect to the tubing.

### ASSEMBLED VIEW



1. Polyethylene Yellow Jacketing
2. Stainless 304 Corrugated Tubing
3. Mechanical Nut
4. Mechanical Fitting
5. Silicone O-Ring
6. Stainless Steel Washer
7. Stainless Steel Retainer
8. High Temperature Sealing Gasket



(Patented System #5,845,946,  
#5,857,716, #6,102,445)

## TROUBLE SHOOTING MECHANICAL FITTING

### CORRECTING LEAKS...

- Step 1 - Gradually tighten fitting until leak stops
- Step 2 - If tightening does not stop after reaching maximum torque of 35 lbs or 50 lbs (refer to maximum torque for each size listed below),

### STOP and open assembly and check...

- a. To see if they are properly assembled. If not correct, go thru assembly steps and test again for leaks.
- b. Check to see that no foreign material is in assembly. If so, clean out and re-assemble and test again for leaks.
- c. Check to see that none of the assembly pieces are cracked. If so, replace, re-assemble and test again for leaks.
- d. Optional: use Pipe tape or Pipe Dope on Threaded Ends.

### TORQUING METHOD FOR FIELD ASSEMBLY

To achieve the proper Torque without a torque wrench, first tighten the fitting adapter to the nut until resistance to hand tightening is so that you can no longer continue. Then, using a crescent wrench, tighten to 1/4 to 1/2 turn.

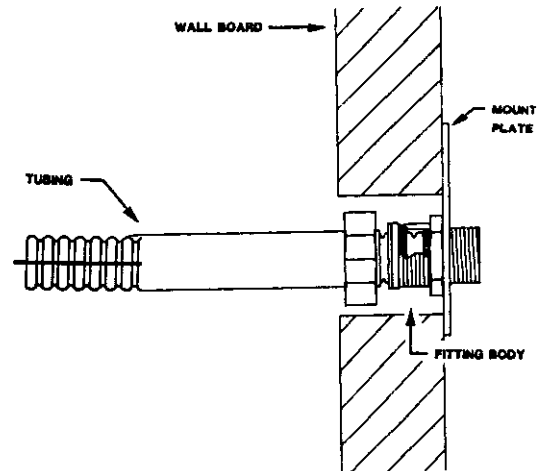
**CAUTION: DO NOT OVER TIGHTEN**

Size of Fitting	Maximum Allowable Tightening Torque
3/8" (10mm)	35 ft.-lb.
1/2" (15mm)	35 ft.-lb.
3/4" (20mm)	50 ft.-lb.
1" (25mm)	50 ft.-lb.
1 1/4" (31mm)	50 ft.-lb.

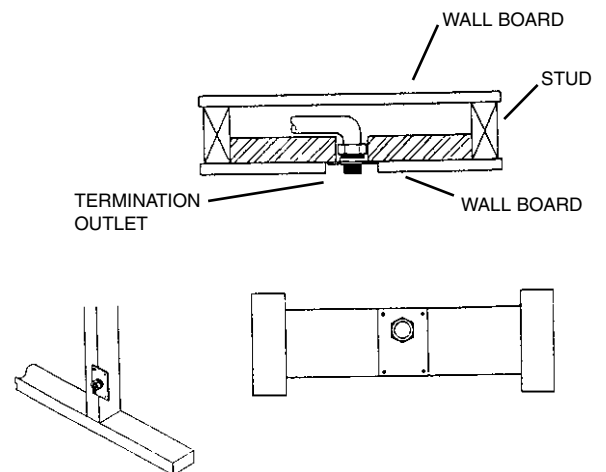
Maximum Allowable Nut Tightening Torques for connecting fittings to corrugated stainless steel tubing

## TERMINATION OUTLET

When connecting to a termination outlet, slide the tube with the nut thru the back side of the termination bracket. Then slide assembly to nut from the bracket ... see illustration below. Each termination, including a valve or tube fitting shall be capped immediately after installation and uncapped when the gas equipment is connected. The termination outlet shall be securely fastened in place during rough installation.



### Termination Outlet Installations



## 4.3 Routing

---

- **Pro-Flex**® CSST can be routed beneath, through and along side floor and ceiling joists. Consideration must be given to future construction possibilities. Alternate locations could include between supply and return air ducts which also provides protection. Care should be taken when installing vertical runs to maintain as much separation as reasonably possible from other electrically conductive systems in the building.
- **Pro-Flex**® can be routed inside hollow wall cavities. This is the preferred for vertical sections of piping rather than horizontal sections. Avoiding horizontal runs through the walls will minimize the need for striker protection.
- **Pro-Flex**® can be routed on top of ceiling joists. This is the preferred method of routing in areas where slab-on-grade construction is prevalent.
- **Pro-Flex**® has passed the ANSI/CSA LC- 1, which include testing for suitability for exposure of CSST piping systems to outdoor environments.

**Note:** Care should be taken when installing any type of fuel gas piping (Inc: CSST, Iron or Copper) to maintain as much separation as reasonably possible from other electrically conductive systems in the building.

a) OUTDOORS:

**Pro-Flex**® when installed outdoors, the external yellow jacketing shall remain intact as much as possible for the given installation. Any portions of the exposed stainless steel tubing shall be wrapped with tape or sleeved to prevent later threats by acids or chloride as cleaning solutions for masonry.

(Note: Self bonding silicone tape is recommended here for its durability.)

b) BURIED or EMBEDDED:

**Pro-Flex**® CSST shall NOT be buried directly in the ground or directly embedded in concrete (patio slabs, foundations or walkways) When necessary, to bury or embed CSST, the tubing shall be routed inside a non-metallic, watertight conduit that has an inside diameter at least 1/2 inch larger than the O.D. size of the CSST tubing. The ends of the conduit installed outdoors, must be sealed at any exposed end to prevent water from entering. NOTE: No mechanical joint fittings are permitted in the conduit. (See page: 30)

c) ALONG SIDE A STRUCTURE:

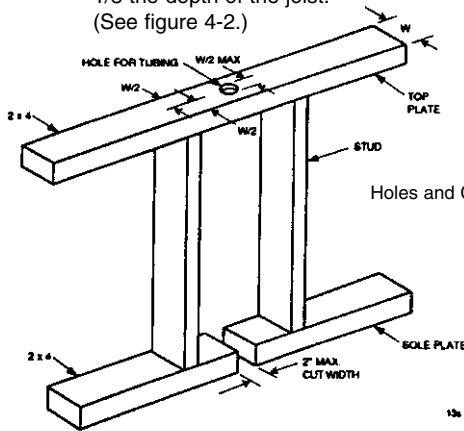
**Pro-Flex**® when installed along the outside of a structure (between the ground and a height of 6 ft) in an exposed condition, the CSST tubing shall be protected from mechanical damage inside a conduit or chase. A conduit or chase is not required if the tubing is installed in a location that will not subject the CSST to mechanical damage.

**Note:** When an excess flow valve is supplied as part of the gas piping system, the CSST manufacturer's design and installation instructions, or instructions supplied with the part by the valve manufacturer, shall include data on sizing and pressure drop across the device as a function of flow (up to the activation flow rate) for each size valve.

**Note:** Consult local building codes as to required separations for CSST from such conductive systems including metallic chimney liners, metallic appliance vents, metallic ducting and piping and electrical cables.

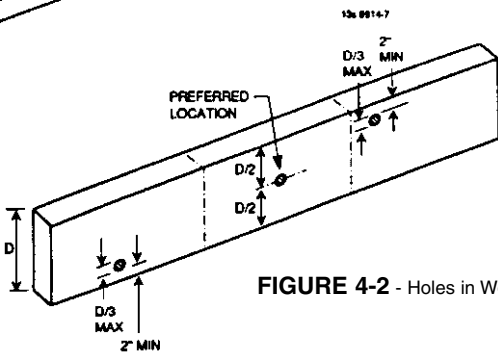
## CLEARANCE HOLES & NOTCHING

- Bored Holes - In locations where CSST is installed through bored holes in joists, rafters, or wood members, holes shall be bored so that the edge of the hole is not less than 2 inc. (50.8 mm) from the nearest edge of the wood member. Where this distance cannot be maintained at any point, the CSST shall be protected by a listed striker plate of the appropriate length and width installed in accordance with the manufacturers installation instructions. The diameter of the bored holes shall be a minimum of 1/2 in. (12.7 mm) larger than the outside diameter of the tubing.
- The size of the hole drilled through top plates, top frame members, and sole plates, to allow the vertical passage of the tubing, shall not exceed 1/2 of the width of the member. The hole should be bored through the center of the member. (See figure 4-1.)
- Where soles or plates are cut for tubing, the width of the cut shall be 1/2 in. (12.7 mm) larger than the outside diameter of the tubing but not greater than 2 in. (50.8 mm), and the tubing must be protected with a listed striker plate of the appropriate length and width installed in accordance with the manufacturers installation instructions. (See figure 4-1.)
- Where a hole is to be bored in a joist, the hole should be located at the centerline, otherwise no closer than 2 in. (50.8 mm) from the nearest edge of the joist, and the hole diameter shall not exceed 1/3 the depth of the joist. (See figure 4-2.)



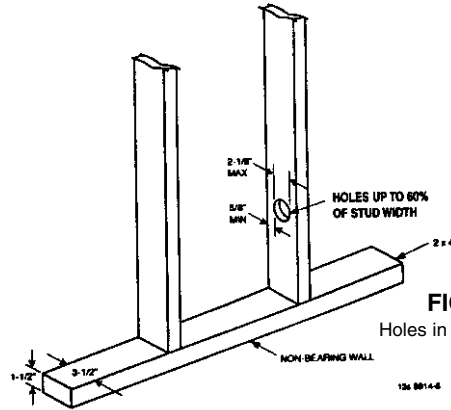
**FIGURE 4-1**  
Holes and Cuts in Top and Sole Plates

Ho

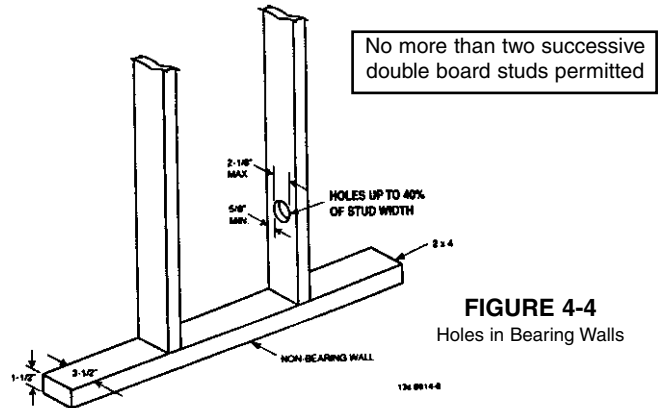


**FIGURE 4-2** - Holes in Wood Joists

- Where holes are to be bored in non-bearing vertical members of the wall framing, the size of such holes shall not be larger than 60 percent of the width of the member. (See figure 4-3.)
- Where holes are to be bored in bearing vertical members of the wall framing, the size of such holes shall not be larger than 40 percent of the width of the member. Holes up to 60 percent of the member's width are permitted if the members are doubled. No more than two successive double bored members are permitted. (See figure 4-4.)
- Installing CSST in notches cut in either the top or bottom of joists are prohibited.



**FIGURE 4-3**  
Holes in Non-Bearing Walls



**FIGURE 4-4**  
Holes in Bearing Walls

The size and depth of installation clearance holes or notches for routing the tubing through wall studs and joists shall comply with the requirements of the local building code.

## CSST THROUGH METAL FRAMING

- When CSST passes through metal members, it shall be installed and protected in accordance as follows:
- When using **Pro-Flex**® Flexible Gas Piping (CSST) thru Metal Enclosures the CSST tubing must be protected by grommets, bushing or armor (Floppy-Flex™), PVC tape, shrink sleeve material or a minimum of four (4) wraps of #10 Mill Duct-Tape. This is to ensure that no physical contact will be made between the metal and the CSST tubing that would cause mechanical wear.

### DRILLING:

Drilling holes should be made approx. 1/2" greater than the outside diameter of the CSST Tubing.

Recommended Installation for Clearance Holes for Routing CSST	
Tubing Size	Drill Hole Size
3/8"	1-1/8"
1/2"	1-3/8"
3/4"	1-1/2"
1	1-3/4"
1 1/4"	2-1/4"

## CONCEALED FITTINGS LOCATION

The **Pro-Flex**® Mechanical Fittings have been tested and listed per the requirements of ANSI/CSA LC-1 for concealed use. The fitting may be used for concealed attachment to appliance valves, branch runs using tee fittings, and length splices.

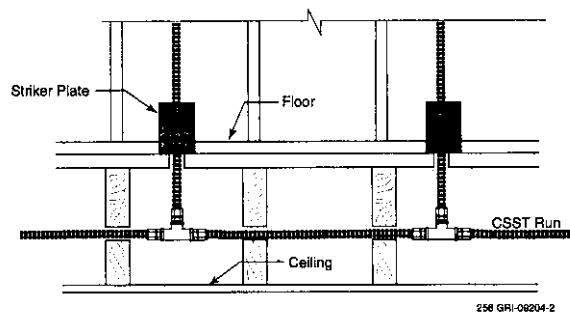
These guidelines address some of the most common situations where concealing the fittings is the only practical alternative. These guidelines cannot address all applications of concealed fittings, but instead, provide typical instructions to demonstrate the principles that apply to fittings listed for installation in concealed locations. (reference National Fuel Gas Code, NFPA 54, Section 3.4.2)

- a) New Installations - When multiple gas outlets are supplied from a single run of CSST, each downstream outlet branch can be connected to the main run using a tee-type fitting which can be located in a concealed location.
- b) Fireplace "key valves" - Flexible piping connections to fireplace key valves can be located in a concealed location, when accessibility is not readily provided.
- c) Exclusion - Manifold stations (2 PSI system), which include the multi-port manifold, shut-off valve and pressure regulator, shall not be installed in concealed locations regardless of the qualifications of the tubing.

### Modifications to Existing Systems

- a) New Ceilings in Unfinished Rooms/Basements - CSST fittings originally installed in accessible ceiling locations can be concealed in the event a ceiling is installed at a later date.

- b) Extensions to Existing Tubing Runs - A concealed tubing can be modified to permit an extension to another appliance location provided there is sufficient capacity to supply both appliances at the same time. If an accessible location for the modification is not available, the existing tubing run can be modified with a tee fitting which will result in a concealed fitting behind the wallboard.



- c) Repairs to Existing Tubing Runs - Damaged tubing runs shall be repaired in accordance with the instructions in this guide. The repair can result in a line splice that may ultimately be located in a concealed location.
- d) Concealed tubing shall be protected from puncture threats, using the shielding devices specified by the manufacturer, at all points of penetration through studs, joists, plates or similar structures. The extent of protection shall be defined as follows:
  1. At points of penetration less than 2 in (50.8 mm) from any edge of a stud, joist, plate, etc., a listed striker plate is required to provide protection at the area of support and within 5 in (127 mm) of each side (if appropriate) of the support.
  2. At points of penetration 2 to 3 in (50.8 mm to 76.2 mm) from any edge of a stud, joist, plates, etc., a listed striker plate is required to provide protection throughout the area of support.
  3. At points of penetration greater than 3 in (76.2 mm) from any edge of a stud, joist, plate, etc., no protection is required.
  4. Tubing routed horizontally through studs shall be protected from puncture threats between the studs using the shielding devices provided.
  5. CSST greater than 1-in (25.4 mm) inside diameter installed within hollow cavity walls of 2" x 4" construction shall be protected along the entire concealed length in the manner and using the shielding devices specified by the manufacturer.
  6. The width of the installed striker plate, at the points of penetration through wall studs, floor joists, plates, sills, etc., shall be out at least 1.5 times the outside diameter of the tubing.

## PROTECTION DEVICES

**PROTECTION IS REQUIRED WHEN THE CSST TUBING IS CONCEALED, CONSTRAINED AND WITHIN 3 INCHES OF A POTENTIAL THREAT.**

**PRO-FLEX®** must be protected where puncture threat exist. Install protection devices, i.e. striker plates as shown, to protect the installed tubing from penetrations by drill bits, nails, screws and in those areas where the tubing is concealed and will not be free to move to avoid such puncture threats.

Shielding is defined as 3" (76.2mm) x 7" (177.8mm) protected area shall be around support points. (when tubing is within 3" (76.2mm) of an interior surface, shielding is required a minimum of 5" (127mm) beyond the support. A 2 x 4 will always require protection because any and all clearance holes for tubing will be less than 3" (76.2mm) away from the 2 x 4 area. Protection/Shielding is required 5" (127mm) beyond the support area when points of penetration are less than 3" (76.2mm) from any surface such as studs, edge of a joist. Refer to figures 4-10, 4-11.

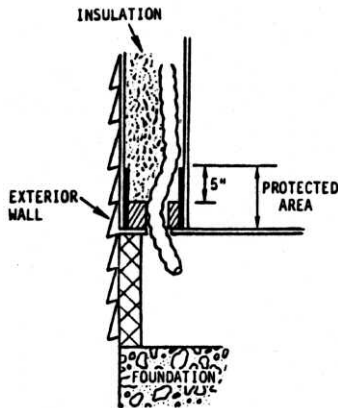


FIGURE 4-10

Long Unsupported Vertical Tubing Rugs (over 3 ft.) within a Hollow Interior Wall Partition. Shielding Required at Support Area When Points of penetration are Less than 2" From any Wall Surface.

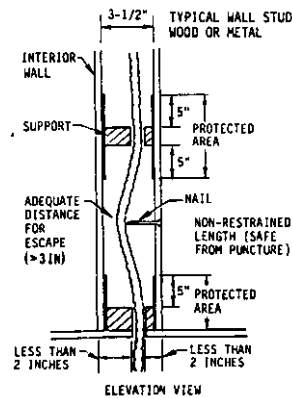
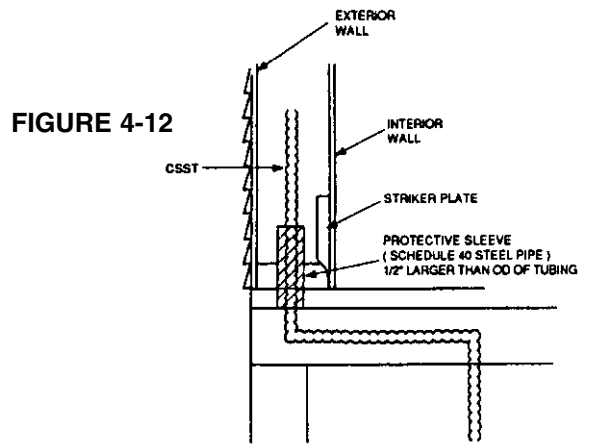


FIGURE 4-11



Where Finished Exterior Wall Does Not Permit Installation of Striker Plate, Protective Sleeve is Required.

Install Floppy-Flex™, strip wound steel conduit, which is another protection device, which can and should be used at points of support such as gas outlet terminations, short tubing runs and where tubing is routed horizontally between studs. Strip wound (Floppy-Flex™) is required along the length within a wall partition when tubing cannot be displaced a minimum of 3" (76.2mm) or if distances between supports are less than 2 ft.

NOTE: The ID of the conduit (Floppy-Flex™) must be at least 1/2" larger than the OD of the CSST Tubing.

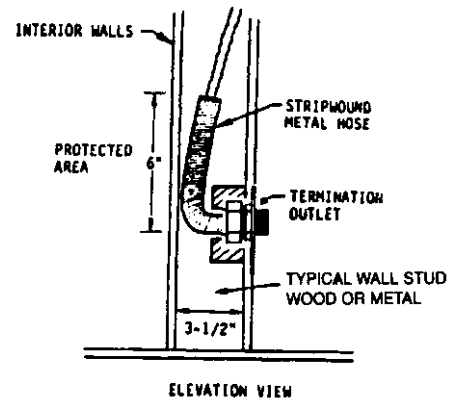


Figure 4-13

When the exterior wall is finished before the installation of the gas tubing and a striker plate cannot be installed, a protective schedule 40 steel pipe sleeve shall be placed around the tubing. The sleeve shall be secured to the sill or stud, be at least 1/2in. (12.7mm) larger in its internal diameter than the O.D. of the CSST, and extend no more than 4 in. (100 mm) above the sill or beyond the stud. A striker plate shall also be placed on the accessible side of the sill or stud as required.

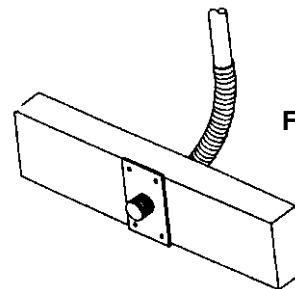


Figure 4-14

Long Unsupported Vertical Tubing Run (over 3 ft.) from a Termination Outlet Within a Wall Partition. Shielding Required At Termination Outlet and Along Tubing Length That Is Non-supported and Cannot Be Displaced a Minimum of 3 in. in the Direction Away From Potential Penetration.

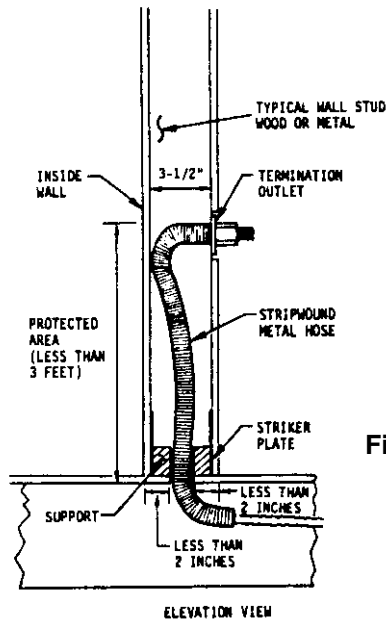


Figure 4-15

Short Unsupported Tubing Run (under 3 ft.) from a Termination Outlet within a Wall Partition. Shielding Required at Support Area (studs) when Point of Penetration are Less than 2 in. from any Outside Surface.

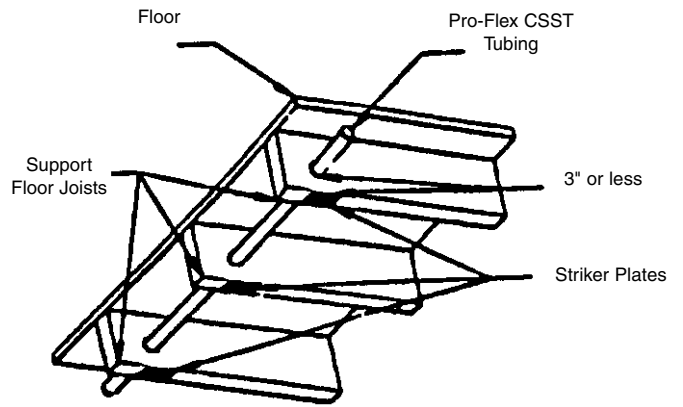


Figure 4-18

CSST Tubing Going Thru Joists Within 3" of Potential Nailing Surface.

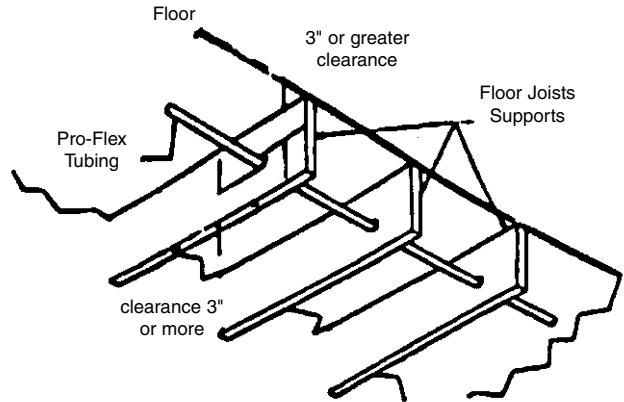


Figure 4-19

CSST Tubing Going Thru Joists With More than 3" of Clearance from Potential Nailing Surface.

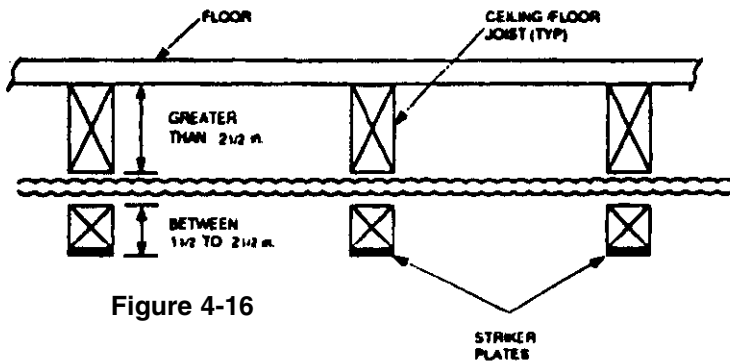


Figure 4-16

Shielding Required at Support Area when Point of Penetration are between 1-1/2 to 2-1/2 in. from any Edge of a Stud, Joist, Plate, etc.

### CSST THROUGH METAL FRAMING:

When using **Pro-Flex**® Flexible Gas Piping (CSST) thru metal Enclosures the CSST tubing must be protected by grommets, bushing or armor (Floppy-Flex™), PVC tape, tube shrink sleeve material or a Minimum of four (4) wraps Of #10 Mil Duct-Tape. This is to ensure that no physical contact will be made between the metal and the CSST tubing that would cause mechanical wear.

# 4.5 Connections/Installations Illustrated

## GUIDELINES FOR INSTALLATION OF PRO-FLEX® (CSST) FLEXIBLE GAS PIPING IN OUTDOOR APPLICATIONS

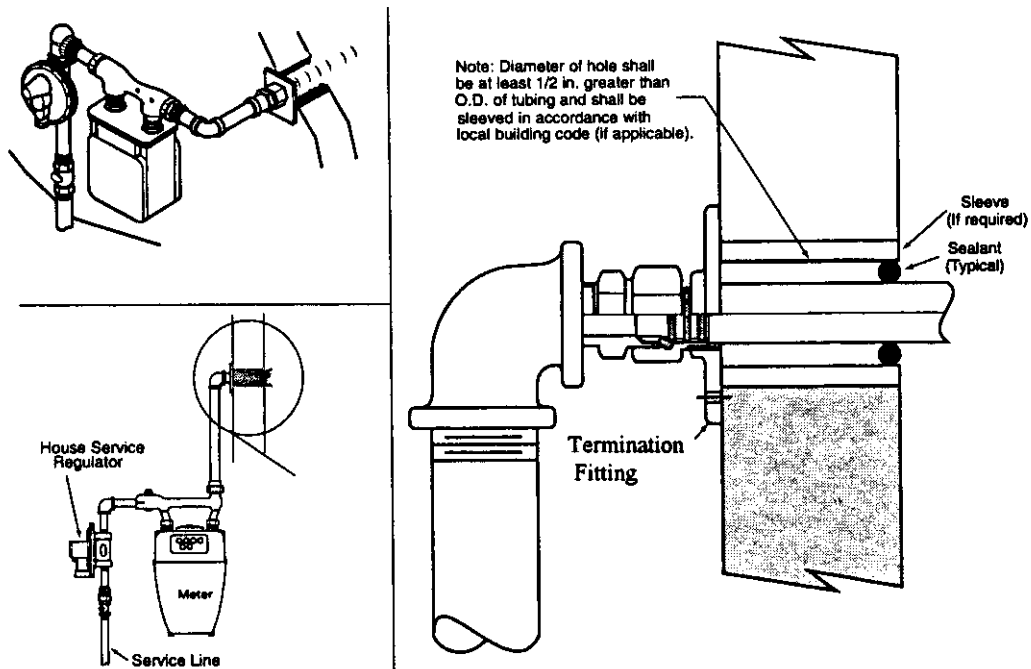
**PRO-FLEX®** tubing and fittings meet all performance requirements for outdoor applications and comply with ANSI/AGA-LC1 standards.

In outdoor applications, the external yellow jacketing on **PRO-FLEX®** should not be removed. All exposed tubing on the outside of a structure or located between the ground and a 6 ft height must be protected in a sealed conduit or weather-tight chase which is routed and secured to avoid mechanical damage.

When buried underground or encased in cement (slabs, foundations, etc.) the tubing must be routed within a plastic watertight conduit. This nonmetallic conduit is to have an inside diameter 1/2 inch larger than the **PRO-FLEX®** tubes outer diameter. Exposed conduit ends must be sealed to prevent entry of water and debris. Local code authority will always take precedence. Therefore make sure you check with your local building authority or code authority having jurisdiction.

### Gas Meter Connections:

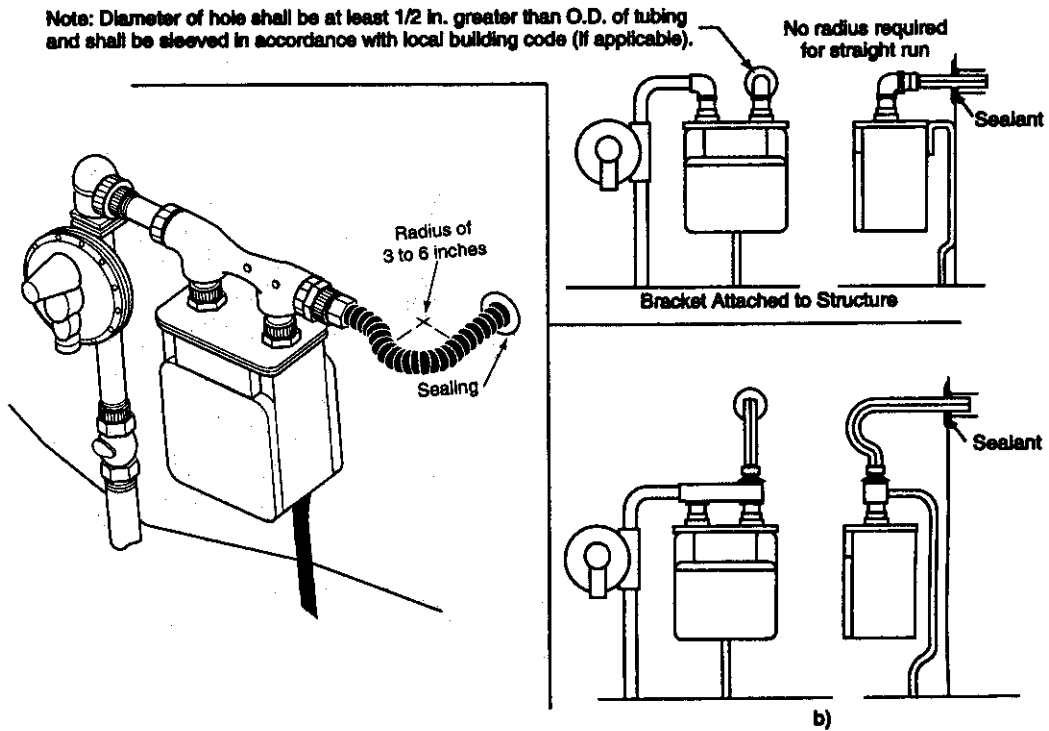
Gas meters are generally supported by the building structure or by framework brackets independent of the structure. Do not use **PRO-FLEX®** CSST as a direct connection to any meter which must be supported by the piping. On structure supported meters, accepted practice is to connect the meter outlet to a termination flange mounted on the exterior wall or to penetrate the exterior wall with a steel pipe and provide a rigid attachment for the meter and **PRO-FLEX®** tubing within the building.



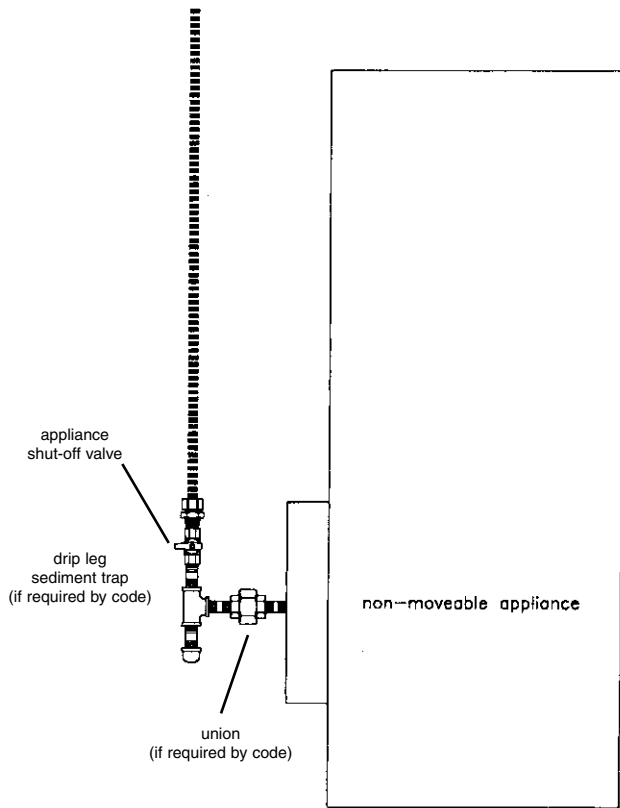
Building Supported Gas Meters

On independently supported meters, **PRO-FLEX®** CSST can, in some locations, be routed through the exterior wall and connected directly to the meter. Direct connections must provide a loop or slack in the tubing to account for building settling and meter movement. Wall penetration must be properly sealed following local code guidelines. **NOTE:** Building codes vary from area to area. Check with your local utility and building codes to verify that meter connections are acceptable. Always remember, local jurisdiction will prevail.

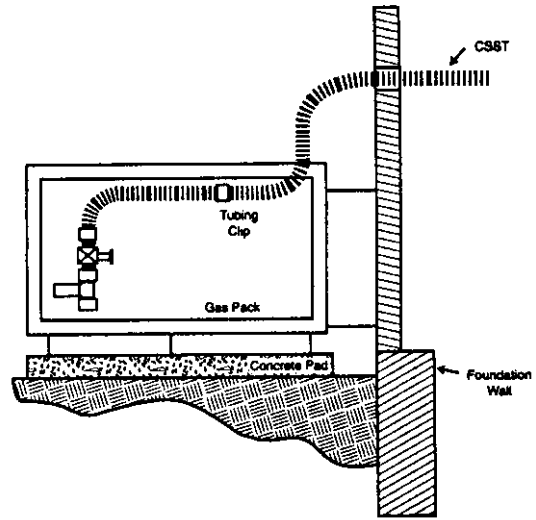
Note: Prior to installing Pro-Flex® directly to a meter, ensure that the local utility allows this practice as some utilities have regulations specifying meter attachments. Any exposed sections of stainless steel piping must be wrapped with a silicone self-bonding tape. This is especially important with masonry and wood frame construction.



Independently Supported Gas Meter



**Fixed Appliance PRO-FLEX® CSST** may be connected directly to non-moveable appliances such as water heaters, furnaces, boilers and island cook-tops without the installation of a termination outlet or flexible appliance connector. All local codes requiring drip legs and shut-off valves must be observed.

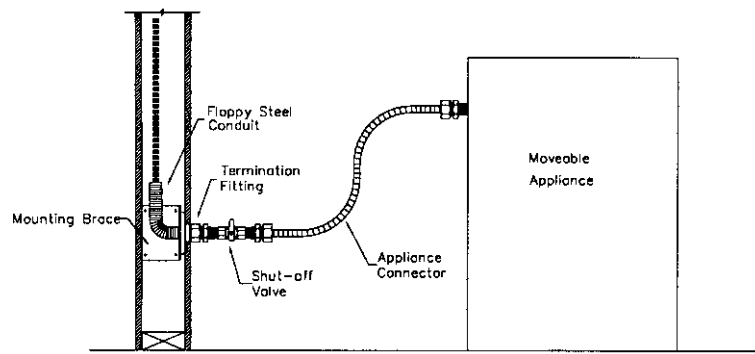


**FIGURE 4-35**  
Pad mounted gas appliance

- Heat Pumps
- Pad Heaters

When appliances such as water heaters, furnaces or fireplaces have metallic vents which extend beyond or protrude through the roof physical contact between the CSST and the appliance cabinet or vent is prohibited. **Pro-Flex®** recommends that all continuous metallic systems be bonded and grounded.

**Moveable Appliance** - A **Pro-Flex®** termination fitting eliminates the need for concealed fittings by allowing CSST to be routed to the exterior of a wall or floor to provide a fixed connection point (stub-out). This fixed connection point allows for the attachment of flexible appliance connectors to moveable appliances such as dryers and ranges.



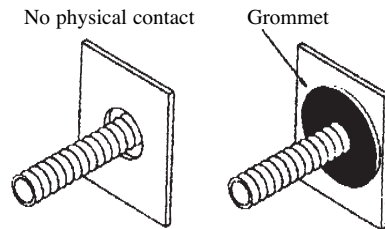
# GAS FIREPLACE INSTALLATIONS

1. **PRO-FLEX**® CSST may be used to deliver gas directly to the valve for gas fireplaces. This is approved for decorative and heat generating fireplaces and for gas logs used in masonry and pre-fabricated fireplaces. **DO NOT** use **PRO-FLEX**® to connect gas log lighters or gas wands for use in al-fuel (wood burning) fireplaces.
2. Where it is necessary to install **PRO-FLEX**® through masonry materials in a fireplace construction, the plastic jacket shall remain intact and the tubing should be routed through sleeving that is appropriate for the application. Sleeving is not required through ceramic liners in decorative heat generating fireplaces.
3. Where it is necessary to install **PRO-FLEX**® through sheet metal enclosures such as gas fireplaces and vibration from motors could cause mechanical wear, the yellow jacket should remain intact and the tubing should be routed or supported to prevent direct contact with the enclosure. If direct contact cannot be avoided, protections such as grommets, bushing or armor (Floppy-Flex™), PVC tape, shrink sleeve material or a minimum of four (4) wraps of #10 Mil Duct-Tape should be used. This is to ensure no physical contact will be made between the metal and the CSST tubing that would cause mechanical wear. *Note:* Remove yellow jacketing only on the length of CSST that may be exposed to the flame within the firebox.

**NOTE:** In some configurations, the corrugated tubing (CSST) feeding gas logs or gas fireplaces can cause a humming or whistle sound. This is due to the gas flow velocity and can usually be prevented by choosing a larger piping size in accordance with the chart below.

<b>Suggested Maximum Capacity for Gas/Log Fireplace</b>			
TUBING SIZE	3/8" (10 mm)	1/2" (15mm)	3/4" (20mm)
FLOW 1,000 BTU	22,000	45,000	80,000

## No Physical Contact



## REQUIREMENTS FOR PENETRATION TO FIRE RATED WALLS AND AIR PLENUMS

**FIRE STOPS:** **PRO-FLEX**® CSST with its polyethylene yellow jacket has been tested to the flame spread and smoke density requirements of ASTM E84 and meets AGA limits imposed for this criteria.

**Pro-Flex**® nonmetallic coating has an ASTM E-84 Flame Spread of less than 25 and ASTM E-84 Smoke Density of less than 50. Other requirements for the fire rated resistive constructions may be imposed by local codes. The qualified/trained installer **must meet local building codes** with respects to flame and smoke density regulations for nonmetallic materials at all times.

## INSTALLATION WITHIN A CHASE

**Pro-Flex**® Tubing shall not be installed within a chase and/or enclosure that includes a metallic appliance vent and/or metallic chimney liner that protrudes through and/or past the roof unless:

- Permitted by local building code,
- An express separation distance as required by local code can be achieved along the entire length.
- The vent and/or liner is directly bonded to the grounding electrode system, AND
- There is no physical contact between the metallic vent and/or liner and the **Pro-Flex**® tubing along the entire length of the vent.

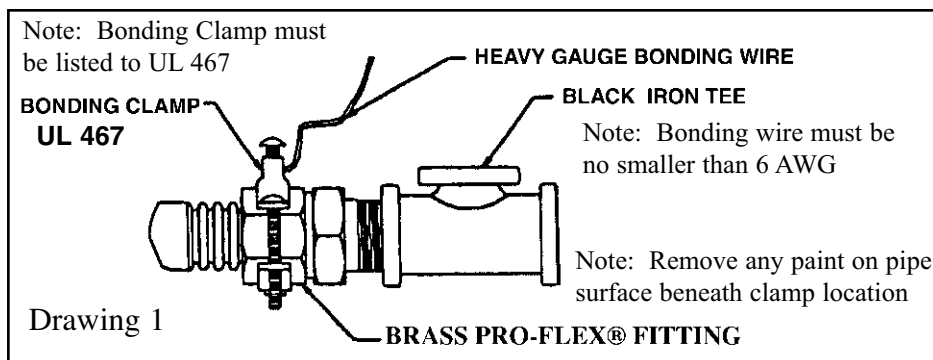
# ELECTRICAL BONDING

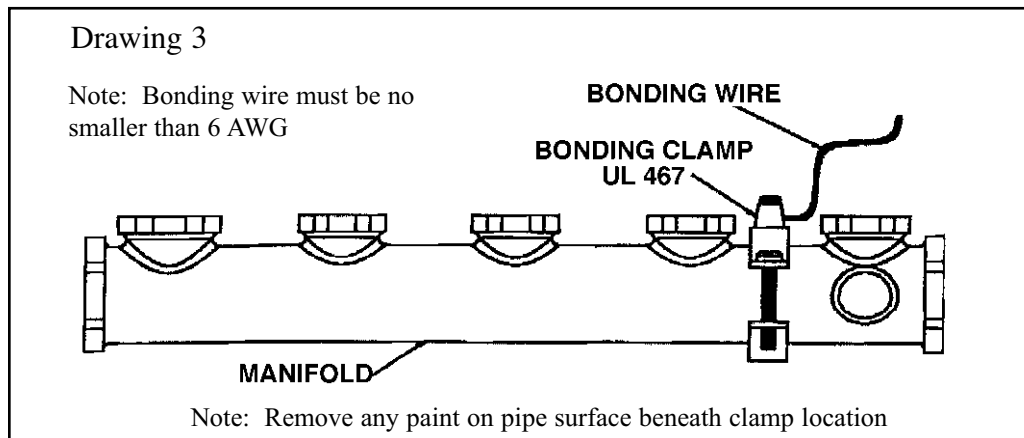
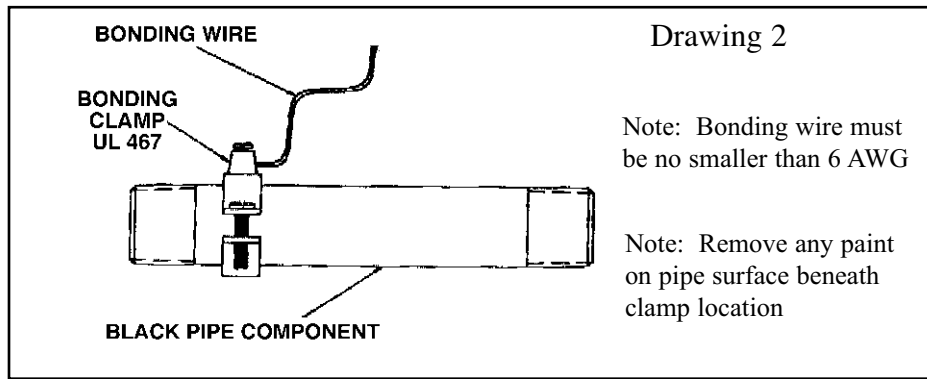
In accordance with the NFPA 54 Section 7.13, Tru-Flex Metal Hose Corp., requires proper bonding of the Pro-Flex® gas-piping systems in a structure to the structure's electrical grounding system. This must be performed by a qualified person recognized by the local jurisdiction as capable of performing such work. These requirements are for all Pro-Flex® CSST installations.

Direct bonding of Pro-Flex® CSST is required as part of the installation of all new CSST natural and LP gas piping systems whether or not the connected gas equipment is electrically powered. This requirement is provided as part of the manufacturer's instructions for single-family and multi-family dwellings. Bonding for commercial applications should be designed by qualified persons knowledgeable in electrical system design and the local electrical code.

Pro-Flex® CSST installed inside or attached to the exterior of a building structure shall be electrically continuous and direct bonded to an effective ground-fault current path. The gas piping systems shall be considered to be direct bonded when installed in accordance with the following guidelines:

- A bonding jumper is permanently and directly connected to the electrical service grounding system. This can be achieved through a connection to the electrical service equipment enclosure, the grounded conductor at the electrical service, the grounding electrode conductor (where of sufficient size) or to the one or more grounding electrodes used.
- A single bond connection is made to the building gas piping downstream of the utility meter or second stage regulator (LP systems), but near the gas service entrance of the structure, or downstream of the gas meter of each individual housing unit within a multi-family structure. (A bonding connection shall not be made to the underground, natural gas utility service line or the underground supply line from a LP storage tank)
- The bonding conductor shall be no smaller than a 6 AWG copper wire or equivalent. Bonding/grounding clamps shall be attached in an approved manner in accordance with NEC and the listing of the clamp. Bonding /grounding clamps shall be listed to UL 467. The point of attachment for the bonding conductor shall be accessible. This bond is in addition to any other bonding requirements as specified by local codes.
- For attachment to the CSST gas piping system, a single bonding clamp must be attached to either a Pro-Flex® brass fitting, a steel manifold or to any rigid pipe between the meter and the first CSST fitting in the system. *The corrugated stainless steel tubing portion of the gas piping system shall not be used as the point of attachment of the bonding conductor at any location along its length under any circumstances. See drawings 1,2 and 3.*





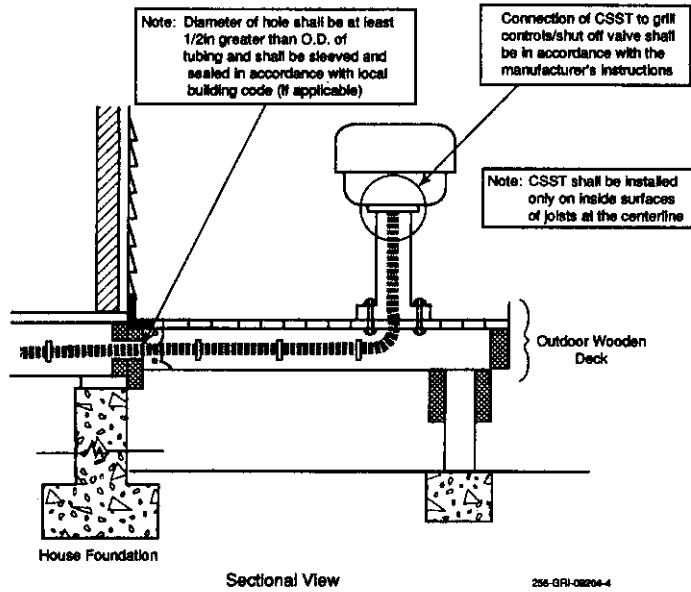
Proper bonding and grounding may reduce the risk of damage and fire from lightning strikes. Lightning is a highly destructive force. Even a nearby lightning strike that does not strike a structure directly can cause metallic systems (such as wiring, piping and ductwork) in the structure to become energized. If these systems are not properly bonded, the difference in potential between the systems may cause the charge to arc from one system to another and cause damage to the CSST. Bonding instructions set forth above should reduce the risk of arcing and its related damages.

Depending upon conditions specific to the location of the structure in which the Pro-Flex® system is being installed, including but not limited to whether the area is prone to lightning activity, the owner of the structure should consider whether a lightning protection system is necessary or appropriate. Lightning protection systems are beyond the scope of this manual, but are covered by NFPA 780, the Standard for the Installation of Lightning Protection Systems, and other standards.

As with all Pro-Flex® guidelines, the techniques outlined within this manual/bulletin are subject to all local fuel gas and building codes.

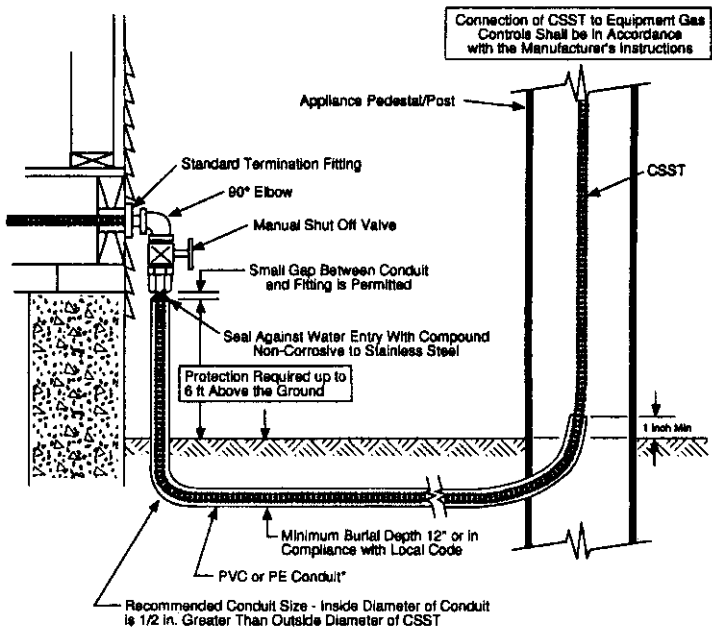
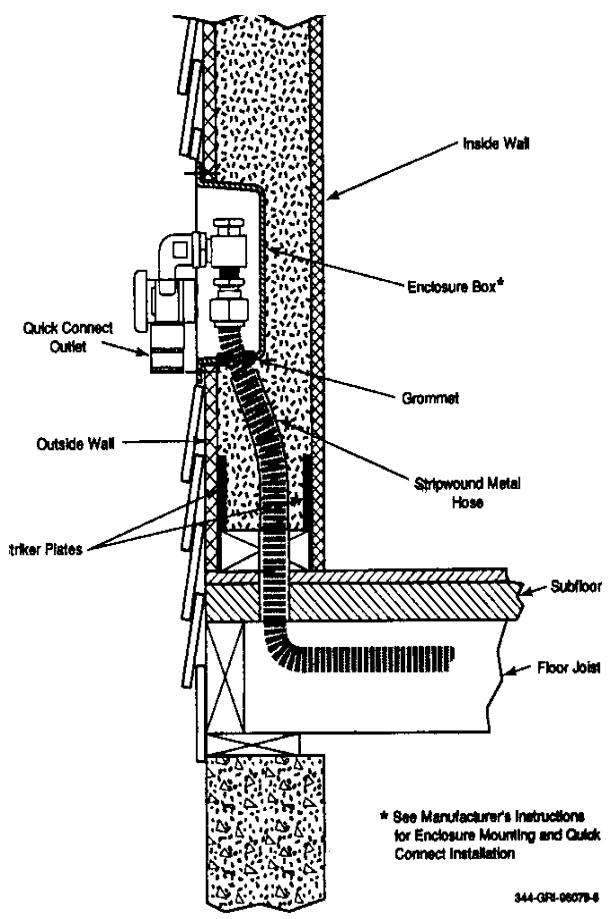
#### **\*LIGHTNING SAFTY WARNING**

PROPERLY BONDING and grounding the Corrugated Stainless Steel Tubing (CSST) system may reduce the risk of damage and fire from lightning strike. Lightning is a highly destructive force. Even a nearby lightning strike that does not strike a structure directly can cause systems in the structure to become electronically energized. Differences in potential between systems may cause the charge to arc between systems. Such arching can cause damage to CSST, including holes. Bonding should reduce the risk of arching and related damage.

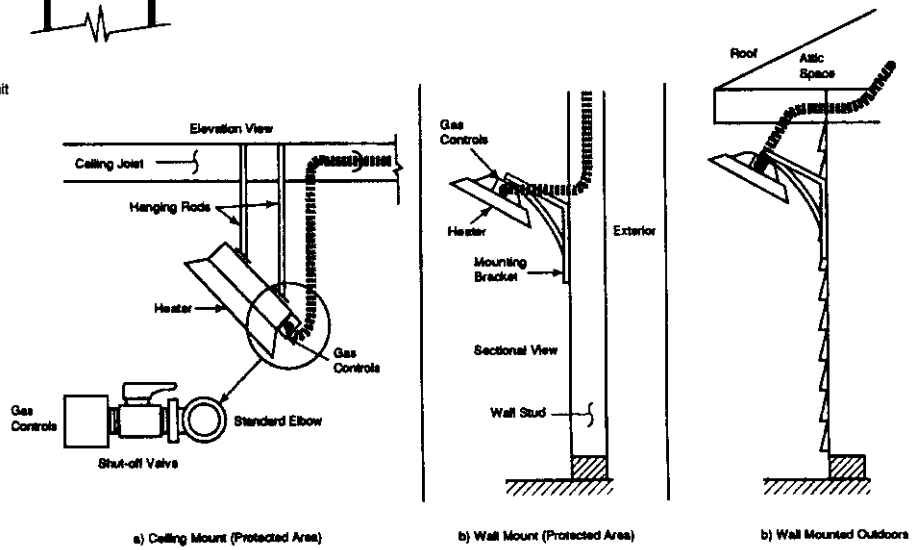


**FIGURE 4-32**

Elevated deck a fixed Pedestal mount grill or gas light - direct connection



**Gas Lamps: FIGURE 4-33**



**FIGURE 4-34**

Ceiling or wall hung infrared heater car ports / patios / decks

## TYPICAL INSTALLATION OF CSST WITH NON-METALLIC CONDUIT BURIED UNDER CONCRETE SLAB

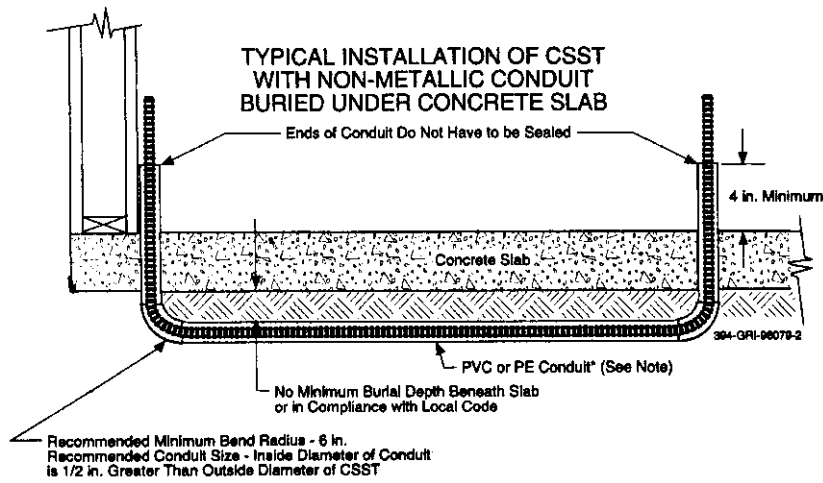


FIGURE 4-40

## TYPICAL INSTALLATION OF CSST WITH NON-METALLIC CONDUIT EMBEDDED IN CONCRETE SLAB

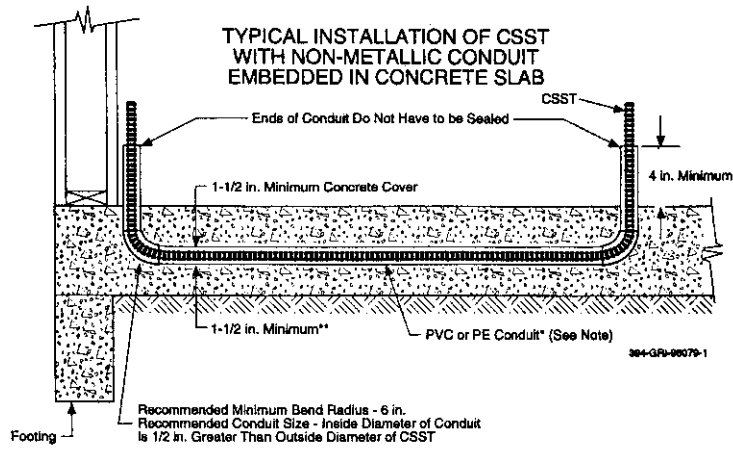
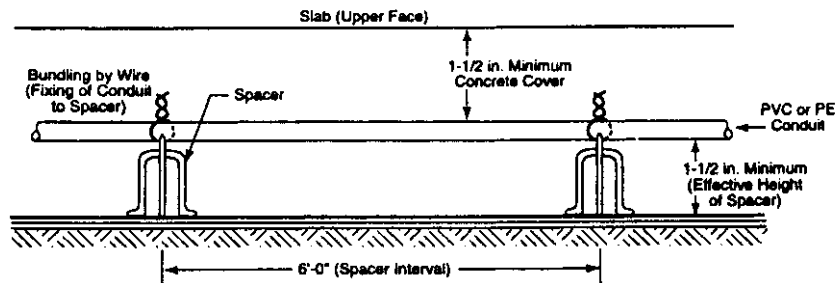
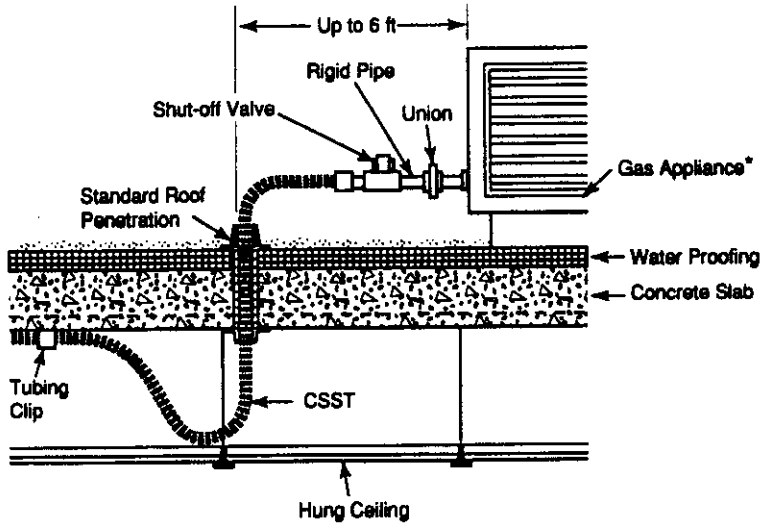


FIGURE 4-41



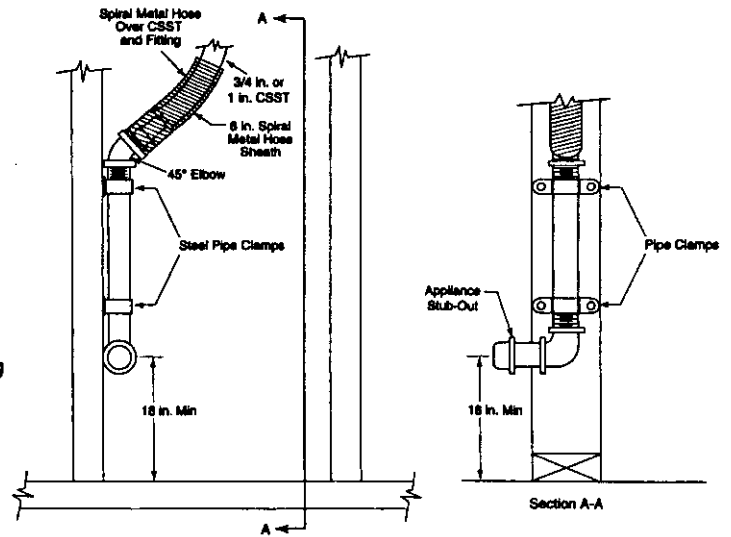


**FIGURE 4-36**

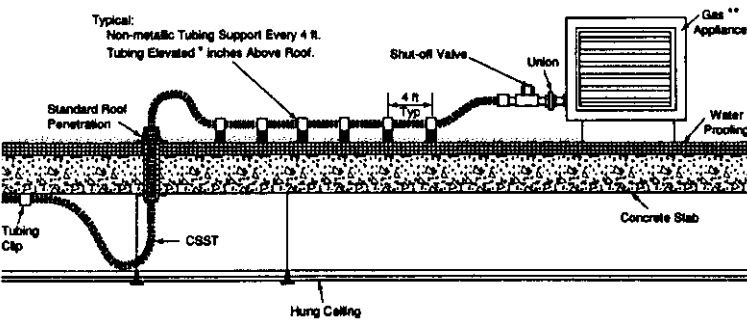
Short (2 to 6 ft.) outdoor connection to roof mounted equipment

**Roof Mounted Equipment: FIGURE 4-36** - No special mechanical protection of the CSST is required for connections to roof top equipment. Whenever possible, roof penetrations shall be located within 6 ft of the equipment to be connected as shown in Figure (4-36). Long runs of tubing shall be supported with nonmetallic blocks every 4-ft. along its outdoor length, and raised above the roof a distance determined by local code/practice (4-37).

Lengths of CSST which run vertically up the side of the building shall be protected in accordance with the guidelines for outdoor installations.



**FIGURE 4-38**  
Appliance termination/stub-out



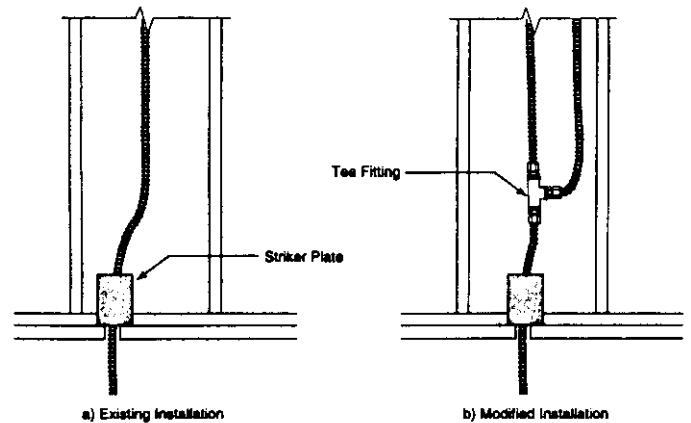
\* Height of elevation based on local plumbing/building code requirements and/or winter ice buildup.

\* Height of elevation based on local plumbing/building code requirements and/or winter ice buildup

\*\*When the equipment manufacturer requires the use of a flexible connector, the CSST shall be installed in a fashion similar to that shown on Figure 4-35.

**FIGURE 4-37**

Long outdoor connection to roof mounted equipment



**FIGURE 4-39**  
Extension of existing tubing run

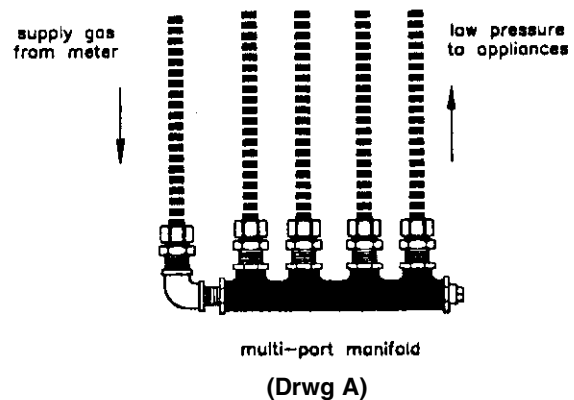
CSST fittings originally installed in accessible ceiling locations may become concealed at a later date if a permanent ceiling is installed. Precautions shall be taken to insure that the tubing and fittings to be concealed are adequately protected from puncture in accordance with the manufacturer's instructions for the installation of mechanical protection devices.

## 4.6 Manifold Stations

Manifolds are installed where multiple runs are made from a common location in a parallel arrangement. The manifold may be manufactured from a one piece, malleable iron or brass casting, or a welded fabrication of steel subcomponents or an assembly of approved, malleable iron tees and short nipples. Depending on the location and available space, different mounting arrangements are permitted. A manifold may be mounted on the surface of an interior wall, between open floor joists, in attic spaces, crawl spaces, within a partition wall, or inside an enclosure. The installation of manifold assemblies using a pounds-to-inches regulator must be in accordance with all local codes, and the following guidelines:

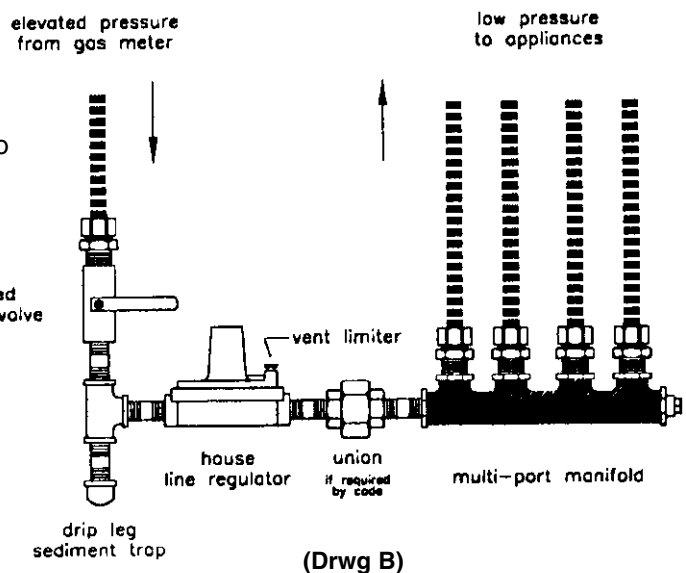
- 1) Standard manifold - low to medium pressure (14" w.c. or less)  
(Drwg A)

Typical Manifold System  
without regulator



- 2) Elevated pressure manifold - A manifold assembly utilizing a pounds-to-inches regulator shall be installed in an accessible, ventilated location so that the regulator can be inspected, maintained and serviced if repair or replacement is required. (Drwg B)

- 3) Behind access panel - For manifold systems that use a pound s-to-inches regulator installed behind an access panel, all tubing penetrations in the cabinet must be sealed, caulked or grommated. The cabinet must be ventilated through the panel/door and not into a wall space.

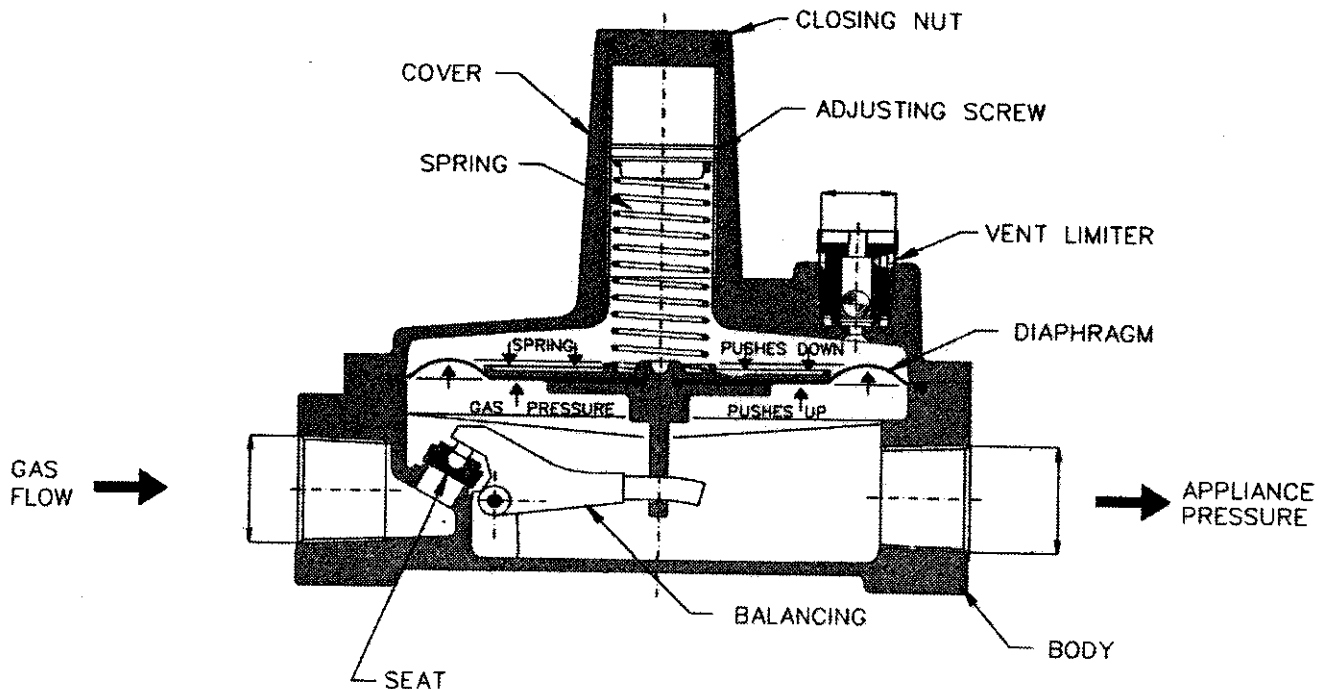


- 4) Open face cabinets - Cabinets which communicate with the normal room environment, may be utilized without the need for ventilation or penetration sealing requirements.

# 4.8 Pressure Regulators

## Description

- a) A piping system for use at gas pressures exceeding 1/2 psi (3.45kPa), but intended to serve equipment rated for 1/2" psi (3.45 kPa) maximum, shall include a gas pressure regulator to limit the downstream supply pressure to 1/2" psi (3.45 kPa), and the installation instructions for the piping system shall specify that such a regulator shall be installed. For system pressures up to 5 psi (34.5 kPa), the regulator shall incorporate construction which will "lock up" under no-flow conditions to prevent excessive downstream pressure build-up. Pressure Drop from Bends and shall comply with the applicable provisions of the Standard for Line Pressure Regulators, ANSI Z21.80 • CSA 6.22. For system pressures above 5 psi (34.5 kPa), the regulator shall comply with a recognized national standard for pressure regulators.
- b) The Maxitrol 325 Series regulator, supplied by **Pro-Flex®** supplies the highest performance as both Line Pressure Regulator and Gas Appliance Regulator. They feature precise regulating control from full flow down to pilot flows. They can be used as a single stage regulator, reducing pounds pressure to normal burner pressure. They can also be used as a line regulator on equipment already fitted with an appliance regulator.
- c) The materials of all component parts are carefully selected and corrosion resistant. The housings are made of durable die cast aluminum, the diaphragm and self-aligning valve seat are made of nitrile rubber which is selected to work at ambient temperatures of -40 to 205 degrees F (-40 to 96 degrees C). All regulators are supplied with vent limiting devices that are made of brass and threaded with a type "O" (NPT Thread).



## Sizing Instructions

- a) Line Pressure Regulator Selection

The Maxitrol Regulator is typically used in a 2 or 5 PSI gas piping installation to reduce supply pressure to the appliance within required operating ranges (typically 4" - 7" WC. natural gas or 10" - 11" LP gas).

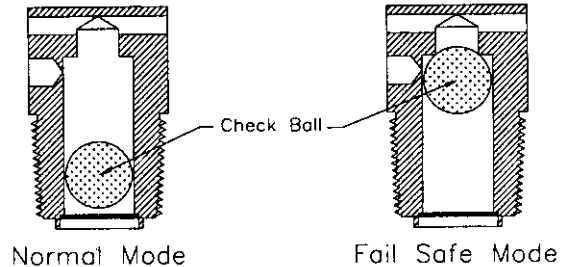
To select the correct regulator for pressure regulation, the following information must be established;

- Available inlet pressure range at the regulator inlet
- Desired outlet pressure
- Required maximum flow rate
- Refer to tables (Page 33) to select the correct regulator to satisfy system requirements.

## Installation

- a) The regulator shall be installed in an accessible location with an approved shut-off valve on the inlet side and a union on the outlet side so that it may be inspected, maintained and serviced if repair or replacement is required.
- b) The regulator is suitable for multi-poise mounting. When using a vent-limiting device however, the regulator must be mounted in a horizontal upright position. All regulators provided by **Pro-Flex®** include a vent limiting device.
- c) The vent limiter is a fail-safe device that permits free air movement above the diaphragm during normal operation. In the unlikely event of a diaphragm rupture, the vent limiting device will limit gas escapement to 1.0 CFH natural gas at 2 PSI and 0.65 CFH LP at 2 PSI. Both values are below the ANSI standard of 2.5 CFH.

Note: The vent-limiting device does not allow gas to escape to the environment during normal mode operation.

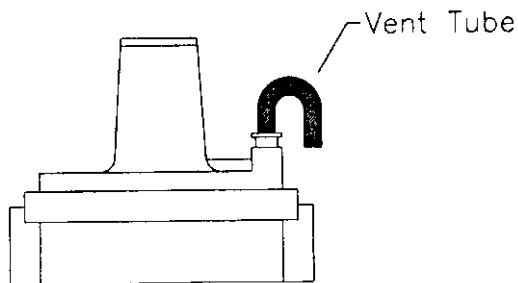


**FIGURE A**

- d) Do not leak test the vent limiter with liquid leak test solution. This action will contaminate the internal ball check mechanism or plug the breathing hole resulting in erratic regulator performance
- e) Using a vent limiter, the maximum inlet pressure is (2 PSI Propane) and (5 PSI Natural Gas).
- f) When using a vent line, the line must be at least the same size as the regulator vent connection, and cannot exceed a length of 30 ft. The vent shall be designed to prevent entry of water, insects or other foreign materials that could cause blockage of the line.. Do not vent to appliance flue, pilot light or building exhaust system.
- g) Maxitrol regulators have a lower temperature limit of -40 degrees F. The lower temperature limit and rust proof construction design enables the regulator to be used for outdoor installations. To minimize the potential for moisture condensation and freezing problems in or around the vent port, **the vent limiting device must be removed for outdoor installations.**

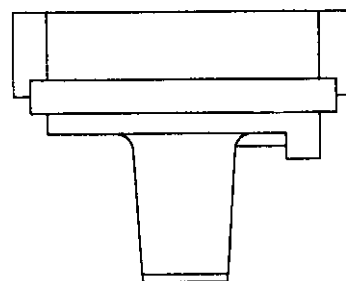
### Outdoor Mounting Options:

The regulator may be mounted upside down with the open vent port facing down. Consideration must be taken to ensure there is adequate clearance for snow buildup.



**FIGURE B**

### Upside Down Vent Limiter Removed



**FIGURE C**

The regulator may be mounted horizontally, with a vent tube installed in the venting port. The end of the tube must be facing downward, and should be designed to prevent water and foreign material from causing a blockage.

## Line Regulator Capacity Tables Natural Gas

Maxitrol Pressure Drop Table				
Capacity @ Pressure Drop - 0.64 sp gr gas expressed in CFH (m <sup>3</sup> /h)				
Model Number	7.0" W.C. (17 mbar)	1/2 psi (34 mbar)	3/4 psi (52 mbar)	1 psi (69 mbar)
325-3	145 (4.0)	204 (5.8)	250 (7.0)	289 (8.2)
325-5A	338 (9.6)	476 (13.5)	583 (16.5)	673 (19.1)
Capacity value for most typical 2 PSI parallel systems when trunk run is sized for 1 PSI pressure drop and a 3/4 PSI drop across regulator				

## Propane

Maxitrol Pressure Drop Table				
Capacity @ Pressure Drop - 1.52 sp gr gas expressed in MBTUH LP				
Model Number	7.0" W.C. (17 mbar)	1/2 psi (34 mbar)	3/4 psi (52 mbar)	1 psi (69 mbar)
325-3	234 (6.4)	328 (9.3)	403 (11.3)	465 (13.2)
325-5A	544 (15.5)	766 (21.7)	939 (26.6)	1084 (30.8)
Capacity value for most typical 2 PSI parallel systems when trunk run is sized for 1 PSI pressure drop and a 1/2 PSI drop across regulator				

### Performance

- a) A performance test should be conducted while operating all appliances at full load. This will test if adequate pressure is reaching each appliance under full-load conditions. To accomplish this, measure the line pressure at the appliance connection while operating the appliance.
- b) The inlet pressure for a typical gas appliances under full load conditions should measure a minimum of 4 inches of water column pressure for natural gas and a minimum 10 inches water column pressure for propane. If these pressure ranges cannot be obtained, a slight adjustment to the service regulator or the pounds-to-inches regulator may be necessary to increase line pressure.

### Adjustment

- a) Adjustment can be accomplished by first removing the regulator seal cap to expose the adjusting screw. Turning the screw clockwise will increase outlet pressure, turning it counter-clockwise will decrease pressure.
- b) If spring adjustment will not produce the desired outlet pressure, check to make sure the main supply pressure is adequate. If the main supply pressure is adequate, consult factory for other line-regulator options. Do not continue to turn regulator adjusting screw clockwise if the outlet pressure readings do not continue to increase. **This may result in over-firing due to loss of pressure control, should there be a subsequent increase in inlet pressure.**
- c) The 2 PSI system pounds-to-inches regulator can be adjusted with an outlet pressure ranging between 7 to 9 inches water column pressure for natural gas and 10 to 12 inches water column for propane. The regulator must be adjusted according to the manufacturers recommended procedure. A pressure gauge mounted just downstream of the regulator can monitor the set pressure under various loads.
- d) The regulator outlet is pre-set and labeled at the factory for either 8" natural gas or 11" propane.
- e) The average natural gas appliance is designed to operate at 3 to 4 inches water column pressure, and a pressure difference of 1 to 2 inches of water column across the appliance regulator which will prevent slow regulator response. Thus, the appliance regulator will operate best at 4 to 6 inches W.C. inlet pressure. The pounds-to-inches system regulators for natural gas are set to deliver 8 inches of W.C. outlet pressure under load to allow for 3 inches of W.C. pressure drop in the tubing.
- f) The average propane gas appliance is designed to operate at 10 to 10-1/2 inches water column pressure. Thus, the pounds-to-inches regulators for propane gas are set to deliver 11 inches water column outlet pressure under load to allow for 0.5 inches water column pressure drop in the tubing.

# 5.0 Inspection and Testing of Installed CSST

## Pressure Testing and Inspection Procedure

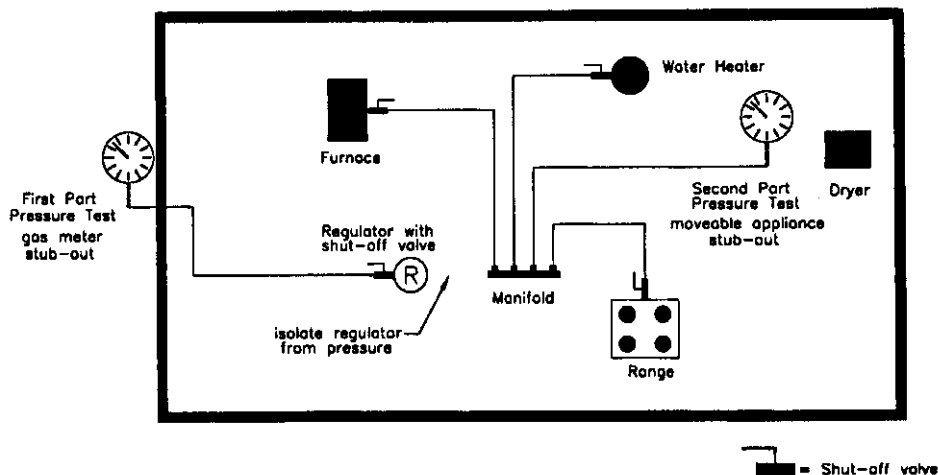
- a) The final installation must be inspected and tested for leaks in accordance with the local / state codes. In the absence of local restrictions test in accordance with the procedures specified in Part 4 of the National Fuel Gas Code, ANSI Z223.1 / NFPA 54, and / or the Natural Gas and Propane Installation Code, CSA B149.1, or the International Fuel Gas Code, or in accordance with the requirements of the applicable local codes. The installed gas piping system shall not exhibit any loss of pressure during the field pressure test. When local codes are more stringent, local codes must be followed.

Note: Remove or isolate the pound-to-inches pressure regulator for system pressure test. Subjecting the regulator to pressures greater than 10 PSI could damage the regulator and will not expose the downstream tubing to the correct test pressure.

- b) Pressure testing must be performed during rough construction of the facility (before interior walls are finished). This will permit a more complete inspection of the piping system during the pressure testing.
- c) Do not connect appliances or pressurize with fuel gas until after the pressure test has been performed.
- d) All gas outlets for appliance connections should be capped during pressure testing.
- e) A 2 PSI system usually requires a pressure test of 10 PSI or greater, depending on local code. In this case, the regulator must be removed or isolated prior to pressure testing. The test may be performed as a one-part test replacing the regulator with suitable "jumper" pipe length for pressure testing the entire system. Or a two-part test may be performed as shown in figure below.

- The first test is performed on the elevated pressure section, between the meter connection and the pounds-to-inches house line regulator.
- The second test is performed on the low-pressure section, between the outlet of the pounds-to-inches house line regulator and the gas appliance outlets.
- For a "two-part" test, it is important to remember to close both gas "shut-off" valves to avoid damage to the regulator.

- f) Electrical bonding must be in place as described on page 28 under "Electrical Bonding/Grounding."



- g) Most jurisdictions also require an additional pressure or leakage test performed after the construction is completed and finished interior walls are in place. The leakage test procedure is generally performed by the gas utility at the time of setting their meter. This test is performed to assure no damage was done to the tubing during the closing-in construction process, and is typically required before gas service is initiated.

## **Appliance Connection Leakage Check Procedure**

After the final pressure test, inspection and final construction is complete (finished interior walls) connect the appliances to the tubing system. This connection can be made using a stainless steel flexible connector for movable appliances such as a dryer or range, or with CSST tubing, or rigid black pipe for fixed appliances. Turn the gas on at the meter and inspect for leakage before operating the appliances.

- a) Connections made at the appliances should be leak checked with a chloride-free bubble solution.
- b) Before placing the appliances in operation, the tubing system should be purged. This displaces the air in the system with fuel gas. Be sure to vent into a well-ventilated area.

NOTE: Leak test solutions may cause corrosion to some types of material in the gas tubing system, be sure to water rinse after the test and thoroughly dry all contacted material. Also, the vent limiter should not be leak tested with a liquid test solution. This will contaminate the internal ball check mechanism or plug the breathing hole, resulting in erratic regulator operation.

# 5.1 Repair and Placement of Damaged CSST

## REPAIRING DAMAGED CSST TUBING & FITTINGS

### Repair Classifications:

**FITTINGS:** Leaking fittings should be repaired in accordance with the manufacturer's installation instructions. In some cases, the entire fitting or parts of the fitting must be replaced totally.

**CSST TUBING:** If the tubing is damaged, the severity of damage and if necessary, the method of repair shall be determined as follows:

- a. Tubing shall be repaired if damaged due to a puncture of any kind from nails, screws or drill bits.
- b. Tubing shall be repaired if significantly damaged due to impact or crushing as indicated in figure 4-44.
- c. Tubing shall be repaired if bent beyond its minimum bend radius and there is a crease or kink in the tubing. (See figure 4-45)
- d. No repairs or replacements of tubing is necessary if the tubing is only slightly dented due to minor impact or crushing. (See figure 4-46)



FIGURE 4-44 – Repair Necessary

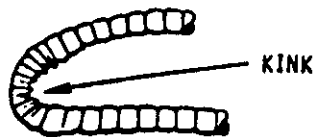


FIGURE 4-45 – Repair Necessary



FIGURE 4-46 – Repair Unnecessary

No significant damage to the tubing due to minor impact or crushing

## METHODS OF REPAIR

There are different methods of repair which are discussed below depending on the nature and severity of the damage.

The Installer must determine the most reliable and economical method of repair using one of the following methods.

**Replace the entire tubing run.** When the tubing run is short and easily accessible, it can be repaired faster and economically by replacing the whole run versus repairing only the damaged section. Replacement in this instance is the preferred method because extra fittings are not required.

**Repairing damaged section.** Damaged tubing shall be repaired by methods listed below.

- a. Remove the section of tubing which is damaged and connect the new ends with a union fitting as shown in figure 4-47 Use this repair method if the damage section is small and there is enough slack tubing in the run to makeup the damaged length.



Typical Tubing Splice with Standard Coupling

**FIGURE 4-47**

# 6.0 Sizing Tables

## NATURAL GAS LOW PRESSURE

Locate proper sizing table based on total pressure drop allowed in piping system by local utility for each installation.

**CAPACITY TABLES OF CSST – TABLE 1**

Maximum Capacity of Pro-Flex® CSST in Cubic Feet per Hour of Gas Gas Pressure: 6 – 7 inches WC (1/4 psig) Pressure Drop: 0.5 inch WC (Based on a 0.6 Specific Gravity Gas)

Tube Size	Tubing Length (feet)																	
	(EHD)	5	10	15	20	25	30	40	50	60	70	80	90	100	150	200	250	300
3/8"	15	64	45	37	32	29	26	23	20	18	17	16	15	14	12	10	9	8
1/2"	18	95	68	56	49	44	40	35	32	29	27	25	24	23	19	16	14	13
3/4"	25	283	200	163	141	126	115	100	89	81	75	70	66	63	51	44	40	36
1"	31	626	424	337	287	253	228	194	171	154	141	131	123	116	92	78	69	62
1 1/4"	37	950	671	547	474	423	386	334	299	273	252	236	222	211	172	149	133	121

\*Table includes losses for four 90 degree bends and two (2) end fittings. Tubing runs with larger numbers of bends and/or fitting shall be increased by an equivalent length of tubing according to the following formula:

$$L = 1.3 (n) \quad L = \text{is the additional length (ft.) of tubing to be added to actual run.} \quad n = \text{is the number of additional fittings and/or bends.}$$

**CAPACITY TABLES OF CSST – TABLE 2**

Maximum Capacity of Pro-Flex® CSST in Cubic Feet per Hour of Gas Gas Pressure: 6 – 7 inches WC (1/4 psig) Pressure Drop: 1.0 inch WC (Based on a 0.6 Specific Gravity Gas)

Tube Size	Tubing Length (feet)																	
	(EHD)	5	10	15	20	25	30	40	50	60	70	80	90	100	150	200	250	300
3/8"	15	90	64	52	45	41	37	32	29	26	24	23	21	20	16	14	13	12
1/2"	18	132	95	78	68	61	56	49	44	40	37	35	33	32	26	23	20	19
3/4"	25	400	283	231	200	179	163	141	126	115	107	100	94	89	73	63	56	51
1"	31	925	626	498	424	373	337	287	253	228	209	194	181	171	136	116	102	92
1 1/4"	37	1346	950	775	671	600	547	474	423	386	357	334	315	299	244	211	188	172

\*Table includes losses for four 90 degree bends and two (2) end fittings. Tubing runs with larger numbers of bends and/or fitting shall be increased by an equivalent length of tubing according to the following formula:

$$L = 1.3 (n) \quad L = \text{is the additional length (ft.) of tubing to be added to actual run.} \quad n = \text{is the number of additional fittings and/or bends.}$$

## NATURAL GAS

Locate proper sizing table based on total pressure drop allowed in piping system by local utility for each installation.

### CAPACITY TABLES OF CSST – TABLE 3

Maximum Capacity of Pro-Flex® CSST in Cubic Feet per Hour of Gas Gas Pressure: 8 – 10 Inches WC Pressure Drop: 3 Inch WC (Based on a 0.6 Specific Gravity Gas)

Tube Size	Tubing Length (feet)																			
	(EHD)	5	10	15	20	25	30	40	50	60	70	80	90	100	150	200	250	300		
3/8"	15	156	110	90	78	70	64	55	50	45	42	39	37	35	29	25	22	20		
1/2"	18	222	160	132	115	103	95	83	74	68	63	59	56	53	44	38	34	32		
3/4"	25	692	490	400	346	310	283	245	219	200	185	173	163	155	126	109	98	89		
1"	31	1717	1162	925	787	694	626	532	469	424	388	360	337	318	253	215	189	171		
1 1/4"	37	2337	1650	1346	1165	1041	950	822	735	671	621	581	547	519	423	366	327	299		

\*Table includes losses for four 90 degree bends and two (2) end fittings. Tubing runs with larger numbers of bends and/or fitting shall be increased by an equivalent length of tubing according to the following formula:

$$L = 1.3 (n) \quad L = \text{is the additional length (ft.) of tubing to be added to actual run.} \quad n = \text{is the number of additional fittings and/or bends.}$$

### CAPACITY TABLES OF CSST – TABLE 4

Maximum Capacity of Pro-Flex® CSST in Cubic Feet per Hour of Gas Gas Pressure: 11 – 13 Inches WC Pressure Drop: 6 Inch WC (Based on a 0.6 Specific Gravity Gas)

Tube Size	Tubing Length (feet)																			
	(EHD)	5	10	15	20	25	30	40	50	60	70	80	90	100	150	200	250	300		
3/8"	15	220	156	127	110	99	90	78	70	64	59	55	52	50	41	35	31	29		
1/2"	18	308	222	183	160	144	132	115	103	95	88	83	78	74	61	53	48	44		
3/4"	25	979	692	565	490	438	400	346	310	283	262	245	231	219	179	155	138	126		
1"	31	2536	1717	1366	1162	1025	925	787	694	628	574	532	498	469	373	318	280	253		
1 1/4"	37	3310	2337	1906	1650	1475	1346	1165	1041	950	880	822	775	735	600	519	464	423		

\*Table includes losses for four 90 degree bends and two (2) end fittings. Tubing runs with larger numbers of bends and/or fitting shall be increased by an equivalent length of tubing according to the following formula:

$$L = 1.3 (n) \quad L = \text{is the additional length (ft.) of tubing to be added to actual run.} \quad n = \text{is the number of additional fittings and/or bends.}$$

## NATURAL GAS

Locate proper sizing table based on total pressure drop allowed in piping system by local utility for each installation.

### CAPACITY TABLES OF CSST – TABLE 5

Maximum Capacity of Pro-Flex® CSST in Cubic Feet per Hour of Gas Gas Pressure: 13 – 14 inches WC Pressure Drop: 6 inch WC (Based on a 0.6 Specific Gravity Gas)

Tube Size (EHD)	Tubing Length (feet)																	
	5	10	15	20	25	30	40	50	60	70	80	90	100	150	200	250	300	
3/8"	15	220	156	127	110	99	90	78	70	64	59	55	52	50	41	35	31	29
1/2"	18	308	222	183	160	144	132	115	103	95	88	83	78	74	61	53	48	44
3/4"	25	979	692	565	490	438	400	346	310	283	262	245	231	219	179	155	138	126
1"	31	2536	1717	1366	1162	1025	925	787	694	626	574	532	498	469	373	318	280	253
1 1/4"	37	3310	2337	1906	1650	1475	1346	1165	1041	950	880	822	775	735	600	519	464	423

\*Table includes losses for four 90 degree bends and two (2) end fittings. Tubing runs with larger numbers of bends and/or fitting shall be increased by an equivalent length of tubing according to the following formula:

$$L = 1.3 (n) \quad L = \text{is the additional length (ft.) of tubing to be added to actual run.} \quad n = \text{is the number of additional fittings and/or bends.}$$

### CAPACITY TABLES OF CSST – TABLE 6

Maximum Capacity of Pro-Flex® CSST in Cubic Feet per Hour of Gas Gas Pressure: 2 psig Pressure Drop: 1 psig (Based on a 0.6 Specific Gravity Gas)

Tube Size (EHD)	Tubing Length (feet)															
	10	25	30	40	50	75	80	100	150	200	250	300	400	500		
3/8"	15	332	211	193	167	150	123	119	106	87	75	67	62	53	48	
1/2"	18	458	297	272	238	214	176	171	154	127	111	100	91	80	72	
3/4"	25	1488	941	859	744	666	544	526	471	384	333	298	272	235	210	
1"	31	4065	2427	2190	1862	1642	1307	1261	1112	885	752	664	599	509	449	
1 1/4"	37	5040	3181	2903	2513	2246	1833	1774	1586	1294	1120	1001	913	791	707	

\*Table includes losses for four 90 degree bends and two (2) end fittings. Tubing runs with larger numbers of bends and/or fitting shall be increased by an equivalent length of tubing according to the following formula:

$$L = 1.3 (n) \quad L = \text{is the additional length (ft.) of tubing to be added to actual run.} \quad n = \text{is the number of additional fittings and/or bends.}$$

**Caution:** Capacities show in Table 6 may exceed maximum capacity of the regulator. With a 1 psig regulator inlet pressure and a 20 inch WC drop across the regulator (8" WC regulator outlet setting), the maximum flow capacity of a single 325-3 is 252 CFH, while the 325-5A is 587. The use of multiple parallel regulators may be required if permitted by local code.

## NATURAL GAS

Locate proper sizing table based on total pressure drop allowed in piping system by local utility for each installation.

### CAPACITY TABLES OF CSST – TABLE 7

Maximum Capacity of Pro-Flex® CSST in Cubic Feet per Hour of Gas Gas Pressure: 5 psig Pressure Drop: 3.5 psig (Based on a 0.6 Specific Gravity Gas)

Tube Size	(EHD)	Tubing Length (feet)														
		10	25	30	40	50	75	80	100	150	200	250	300	400	500	
3/8"	15	617	392	359	311	279	228	221	198	162	140	126	115	99	89	
1/2"	18	828	537	493	430	387	319	310	279	230	201	180	166	144	130	
3/4"	25	2783	1761	1608	1393	1245	1017	985	881	719	623	557	508	440	394	
1"	31	8228	4912	4433	3770	3325	2647	2552	2251	1791	1524	1344	1213	1031	909	
1 1/4"	37	9452	5967	5445	4713	4213	3437	3328	2975	2427	2101	1878	1714	1483	1326	

\*Table includes losses for four 90 degree bends and two (2) end fittings. Tubing runs with larger numbers of bends and/or fitting shall be increased by an equivalent length of tubing according to the following formula:

$L = 1.3 (n)$        $L$  = is the additional length (ft.) of tubing to be added to actual run.       $n$  = is the number of additional fittings and/or bends.

**Note:** Table 7 does include the effects of pressure drop across the line regulator. If regulator pressure drop exceeds 1 psig across 325-3 or 325-5A regulators, DO NOT USE THIS TABLE. Consult with Tru-Flex Metal Hose Corp. for guidance.

**Caution:** Capacities shown in Table 7 may exceed maximum capacity of the regulator. With a 1.5 psig regulator inlet pressure and a 1 psig pressure drop across the regulator, the maximum flow capacity of a single 325-3 is 298 CFH while the 325-5A is 695 CFH. The use of multiple parallel regulators may be required if permitted by local code.

# Propane

## PROPANE LOW PRESSURE GAS

Locate proper sizing table based on total pressure drop allowed in piping system by local utility for each installation.

### CAPACITY TABLES OF CSST – TABLE 8 Maximum Capacity of Pro-Flex® CSST in Thousands of BTU per Hour of Undiluted Liquefied Petroleum Gas

Gas Pressure: 11 inch WC Pressure Drop: 0.5 Inch WC (Based on a 1.52 Specific Gravity Gas)

Tube Size (EHD)	Tubing Length (feet)																			
	5	10	15	20	25	30	40	50	60	70	80	90	100	150	200	250	300			
3/8"	15	101	72	59	51	46	42	36	32	29	27	25	24	23	19	16	14	13		
1/2"	18	150	108	89	78	70	64	56	50	46	43	40	38	36	30	26	23	21		
3/4"	25	447	316	258	223	200	182	158	141	129	119	111	105	100	81	70	63	57		
1"	31	990	670	533	453	400	381	307	270	244	224	207	194	183	145	124	109	98		
1 1/4"	37	1501	1060	865	748	669	610	528	472	431	399	373	351	333	272	235	210	192		

\*Table includes losses for four 90 degree bends and two (2) end fittings. Tubing runs with larger numbers of bends and/or fitting shall be increased by an equivalent length of tubing according to the following formula:

$$L = 1.3 (n) \quad L = \text{is the additional length (ft.) of tubing to be added to actual run.} \quad n = \text{is the number of additional fittings and/or bends.}$$

### CAPACITY TABLES OF CSST – TABLE 9 Maximum Capacity of Pro-Flex® CSST in Thousands of BTU per Hour of Undiluted Liquefied Petroleum Gas

Gas Pressure: 13 – 14 inches WC (1/2 psig) Pressure Drop: 2.5 WC (Based on a 1.52 Specific Gravity Gas)

Tube Size (EHD)	Tubing Length (feet)																			
	5	10	15	20	25	30	40	50	60	70	80	90	100	150	200	250	300			
3/8"	15	225	160	131	113	101	93	80	72	66	61	57	54	51	42	36	32	29		
1/2"	18	322	232	191	167	150	138	120	108	99	92	86	82	78	64	56	50	46		
3/4"	25	1000	707	577	500	447	408	353	316	288	267	250	235	223	182	158	141	129		
1"	31	2449	1658	1320	1122	990	893	760	670	604	554	514	481	453	361	307	270	244		
1 1/4"	37	3368	2378	1940	1679	1501	1370	1186	1060	967	895	837	789	748	610	528	472	431		

\*Table includes losses for four 90 degree bends and two (2) end fittings. Tubing runs with larger numbers of bends and/or fitting shall be increased by an equivalent length of tubing according to the following formula:

$$L = 1.3 (n) \quad L = \text{is the additional length (ft.) of tubing to be added to actual run.} \quad n = \text{is the number of additional fittings and/or bends.}$$

## PROPANE LOW PRESSURE GAS

Locate proper sizing table based on total pressure drop allowed in piping system by local utility for each installation.

### CAPACITY TABLES OF CSST – TABLE 10 Maximum Capacity of Pro-Flex® CSST in Thousands of BTU per Hour of Undiluted Liquefied Petroleum Gas

Gas Pressure: 2 psig Pressure Drop: 1 psig (Based on a 1.52 Specific Gravity Gas)

Tube Size (EHD)	Tubing Length (feet)															
	10	25	30	40	50	75	80	100	150	200	250	300	400	500		
3/8"	15	525	334	305	265	237	194	188	161	138	119	107	98	85	76	
1/2"	18	724	469	431	376	338	279	271	233	201	175	158	145	126	113	
3/4"	25	2353	1488	1359	1177	1053	860	832	710	608	526	471	430	372	333	
1"	31	6426	3836	3462	2944	2597	2067	1993	1666	1399	1190	1049	947	805	710	
1 1/4"	37	7959	5025	4585	3968	3548	2894	2802	2388	2044	1769	1581	1443	1249	1116	

\*Table includes losses for four 90 degree bends and two (2) end fittings. Tubing runs with larger numbers of bends and/or fitting shall be increased by an equivalent length of tubing according to the following formula:

$L = 1.3 (n)$  L = is the additional length (ft.) of tubing to be added to actual run. n = is the number of additional fittings and/or bends.

**Caution:** Capacities show in Table 12 may exceed maximum capacity of the regulator. With a 1 psig regulator inlet pressure and a 15 inch WC drop across the regulator (13 inch WC regulator outlet setting), the maximum flow capacity of a single 325-3 is 342,000 BTU/hr., while the 325 5A is 796,000 BTU/hr. The use of multiple parallel regulators may be required if permitted by local code.

**Note:** Table 12 does not include the effects of pressure drop across the line regulator. If regulator pressure drop exceeds 17 inch WC across 325-3 or 325-5A regulators, **DO NOT USE THIS TABLE.** Consult with Tru-Flex Metal Hose Corp. for guidance.

### CAPACITY TABLES OF CSST – TABLE 11 Maximum Capacity of Pro-Flex® CSST in Thousands of BTU per Hour of Undiluted Liquefied Petroleum Gas

Gas Pressure: 5 psig Pressure Drop: 3.5 psig (Based on a 1.52 Specific Gravity Gas)

Tube Size (EHD)	Tubing Length (feet)															
	10	25	30	40	50	75	80	100	150	200	250	300	400	500		
3/8"	15	976	621	567	492	441	361	349	298	256	222	199	182	157	141	
1/2"	18	1310	849	779	680	612	505	490	421	364	317	286	262	229	206	
3/4"	25	4400	2784	2541	2201	1969	1608	1557	1328	1137	985	881	804	695	623	
1"	31	13007	7766	7008	5960	5257	4184	4035	3372	2832	2409	2124	1917	1630	1438	
1 1/4"	37	14928	9424	8600	7443	6654	5429	5256	4479	3833	3318	2966	2707	2343	2094	

\*Table includes losses for four 90 degree bends and two (2) end fittings. Tubing runs with larger numbers of bends and/or fitting shall be increased by an equivalent length of tubing according to the following formula:

$L = 1.3 (n)$  L = is the additional length (ft.) of tubing to be added to actual run. n = is the number of additional fittings and/or bends.

**Caution:** Capacities show in Table 13 may exceed maximum capacity of the regulator. With a 1.5 psig regulator inlet pressure and a 1 psig pressure drop across the regulator (14 inch WC regulator outlet setting), the maximum flow capacity of a single 325-3 is 467,000 BTU/hr., while the 325-5A is 1,088,000 BTU/hr. The use of multiple parallel regulators may be required if permitted by local code.

**Note:** Table 13 does not include the effects of pressure drop across the line regulator. If regulator pressure drop exceeds 1 psig across 325-3 or 325-5A regulators, **DO NOT USE THIS TABLE.** Consult with Tru-Flex Metal Hose Corp. for guidance.

## SIZING TABLES AND PRESSURE DROP CHARTS

### IRON PIPE CAPACITY TABLES

Maximum Capacity of Steel IPS Pipe in Cubic Feet Per Hour with a  
Gas Pressure of 0.5 psi or less and a Pressure Drop of 0.5 in. WC  
(based on a 0.60 Specific Gravity Gas)

Nominal Iron Pipe Size (in.)	Internal Diameter (in.)	Tubing Length (feet)															
		10	20	30	40	50	60	70	80	90	100	125	150	175	200		
1/4"	0.364	43	29	24	20	18	16	15	14	13	12	11	10	9	8		
3/8"	0.493	95	65	52	45	40	36	33	31	29	27	24	22	20	19		
1/2"	0.622	175	120	97	82	73	66	61	57	53	50	44	40	37	35		
3/4"	0.824	360	250	200	170	151	138	125	118	110	103	93	84	77	72		
1"	1.049	680	465	375	320	285	260	240	220	205	195	175	160	145	135		
1 1/4"	1.380	1400	950	770	660	580	530	490	460	430	400	360	325	300	280		
1 1/2"	1.610	2100	1460	1180	990	900	810	750	690	650	620	550	500	460	430		
2"	2.067	3950	2750	2200	1900	1680	1520	1400	1300	1220	1150	1020	950	850	800		
2 1/2"	2.469	6300	4350	3520	3000	2650	2400	2250	2050	1950	1850	1650	1500	1370	1280		
3"	3.068	11000	7700	6250	5300	4750	4300	3900	3700	3450	3250	2950	2650	2450	2280		
4"	4.026	23000	15800	12800	10900	9790	8800	8100	7500	7200	6700	6000	5500	5000	4600		

\*Table reproduced from National Fuel Gas Code NFPA-54

## Reference Data

### SPECIFIED GRAVITY FACTOR FOR NATURAL GAS

Pressure Conversion Factors			Fuel Gas Information		
1/4 psi =	6.921 in. w.c. =	(approx. 7" w.c.)	BTU per Cubin Foot = Specific Gravity =	Natural Gas	Propane
1/2 psi =	13.842 in. w.c. =	(approx. 14" w.c.)		1000	2516
1 psi =	27.684 in. w.c. =	(approx. 28" w.c.)		0.60	1.52
2 psi =	55.368 in. w.c. =	(approx. 56" w.c.)			
5 psi =	138.42 in. w.c. =	(approx. 140" w.c.)			
			Note: to determine the CFH for Natural Gas, divide the BTU load by 1000. To determine the CFH for Propane, divide the BTU by 2516.		

Gas piping systems that are to be supplied with a gas of a specific gravity other than 0.60 for natural gas or 1.52 for propane shall apply a specific gravity factor. This conversion is accomplished by multiplying the flow capacities given in Tables 1 through 15 and on the pressure drop graph by the appropriate multiplier shown in the tables shown below. If the exact specified gravity is not shown in the table, use the next higher specified gravity shown.

Specific Gravity	Multiplier	Specific Gravity	Multiplier
0.35	1.31	1.00	0.78
0.40	1.23	1.10	0.74
0.45	1.16	1.20	0.71
0.50	1.10	1.30	0.68
0.55	1.04	1.40	0.66
0.60	1.00	1.50	0.63
0.65	0.96	1.60	0.61
0.70	0.93	1.70	0.59
0.75	0.90	1.80	0.58
0.80	0.87	1.90	0.56
0.85	0.84	2.00	0.55
0.90	0.82	2.10	0.54

# 7.0 Technical Data Sheet

## PRO-FLEX® C.S.S.T. SPEC / DATA SHEET

All system components are CSA approved

### PRO-FLEX® TUBING

**TUBING:** ASTM A240/A240M-95A Type 304 Stainless Steel  
**COATING:** Polyethylene Jacketing

### PRO-FLEX® FITTINGS

**MALE & FEMALE FITTINGS:** C360 Brass  
**BRASS UNION FITTING:** C360 Brass  
**REDUCER/INCREASERS:** C360 Brass  
**TERMINATION PLATES:** 1018 Low Carbon Steel  
**RETAINER RING:** ASTM A240/A240M-95A Stainless Steel  
**WASHER RING:** ASTM A240/A240M-95A Stainless Steel  
**SILICONE O-RING:** Silicone Rubber, proprietary material  
**HI-TEMP GASKET:** The gasket is made from a non-asbestos, proprietary material. The gasket is compressed during the assembly processes and should be inspected and replaced, if necessary, when reusing the fitting.

### PRO-FLEX® ACCESSORIES

**STRIKER PLATES:** Manufactured of 16 ga hardened steel  
**MANIFOLDS:** Standard 150 lb. Malleable Iron Threaded Fittings Single tee and multiple tee manifold assemblies.  
**VALVES:** Ball valves which meet the ANS/ASM B 16.33 or CGA 9.1-M88 as approved shutoff valves for use with CSST tubing.  
**REGULATOR:** Maxitrol 325-3 or 325-5A or equivalent.  
**METAL CONDUIT:** **Floppy-Flex™** manufactured by Tru-Flex Metal Hose Corp. Galvanized strip-wound metal conduit used as a protection device.

# 8.0 CSST Installation Checklist

## Description

Corrugated Stainless Steel Tubing (CSST) has been design certified by CSA (formerly know as AGA, The American Gas Association Laboratory since 1990) for use as a fuel gas piping system. CSST has been tested per ANSI/CSA-LC1 as required for approval and is listed as an approved gas piping material in the National Fuel Gas Code-NFPA 54, BOCA National Mechanical Code, SBCCI Standard Gas Code, and the new International Code Series. Pro-Flex® is a listed product with IAPMO and pursuant to section 302.1 Alternate Materials and Methods of the Uniform Plumbing Code, may be installed with approval from the local administrative authority.

## Approval: Conditions and Requirements

A flexible gas piping system using CSST must be installed **in accordance with all local building codes** and the manufacturer's instructions. The following check list is designed to assist the local administrative authority to perform an inspection of a fuel piping system using corrugated stainless steel tubing.

1. Flexible Gas Piping may only be installed by a Qualified Installer who has successfully completed the manufacturers Training Program. A manufacturer's qualification/training card is required to purchase and install Flexible Gas Piping.
2. Only the components provided or specified by the manufacturer (including strike protection) as part of the piping system are to be used in the installation.
3. CSST routed in a location which is concealed, constrained and within 3 inches of a potential threat will be protected against damage by protection devices listed in the manufacturers Installation/Training Guide.
4. Sizing of the Flexible Gas Piping System must be performed using capacity tables found in the manufacturer's Installation/Training Guide or other code approved CSST capacity tables.
5. CSST should not be connected to moveable appliances. Connection's to moveable appliances such as ranges in clothes dryers should be accomplished with a "flexible appliance connector," such as Home Flex® St. St. Gas Appliance Connectors by Tru-Flex Metal Hose.
6. The Flexible Gas Piping System must be pressure tested for leaks during rough construction in accordance with all local codes. In the absence of local requirements, test in accordance with NFPA 54, National Fuel Gas Code which is 1 1/2 times the maximum working pressure but not less than 3 PSI. To subject the entire CSST system to pressure test, the pressure regulators should be isolated or removed.
7. Regulators are suitable for multi-poise mounting. When using a vent limiting device however, the regulator must be mounted in a horizontal upright position.
8. A manifold assembly utilizing a pounds-to-inches regulator shall include a ball-valve ahead of the regulator and installed in an accessible location so that the regulator can be inspected, maintained and serviced if repair or replacement is required.
9. When installed outdoors, the external jacket shall remain intact as much as possible. Exposed portions of the stainless steel tubing shall be wrapped to provide protection from corrosive threats.
10. For installation buried underground, concrete/asphalt or embedded in concrete, CSST must be routed in a nonmetallic water-tight conduit which has an inside diameter at least 1/2 in. larger than the outside diameter of the tubing. For under concrete/asphalt slab, sleeved CSST must be buried in accordance with all local codes. No mechanical joints are permitted within the conduit.
11. Electrical Bonding must be in place as described on page 28 under "Electrical Bonding/Grounding."

**WARNING:** Improper installation or operation of the system may result in fire, explosion, or asphyxiation. Only the components provided or specified by Tru-Flex Metal Hose Corp., for the use of Pro-Flex® as part of the fuel gas system are to be used in the installation. Use of components from other flexible gas piping systems other than those specified as part of Pro-Flex® system is prohibited and may result in poor system performance and serious bodily injury or property damage.

While every **effort has been made to prepare** this document in accordance with all regional model codes in effect at its printing, Tru-Flex Metal Hose cannot guarantee that the local administrative authority will accept the most recent version of these codes. It is the ultimate responsibility of the qualified installer to determine suitability and acceptance of any building component including gas piping. **Tru-Flex Metal Hose Corp. manufacturers of Pro-Flex® CSST assumes no responsibility for labor or material for installations made without prior determination of local code authority acceptance.**

# 9.0 Terminology

## 1 CONVERSION FACTORS

**INCHES OF WATER COLUMN** (in.-w.c.) - Method by which pressure is measured inches by a manometer or pressure gauge. Used in the gas industry when the pressure is less than 1 psi.

PRESSURE CONVERSION CHART		
1/4 psi =	6.921 in. w.c. =	(approx. 7 w.c.)
1/2 psi =	13.842 in. w.c. =	(approx. 14 w.c.)
1 psi =	27.684 in. w.c. =	(approx. 28 w.c.)
2 psi =	55.368 in. w.c. =	(approx. 56 w.c.)
5 psi =	138.42 in. w.c. =	(approx. 140 w.c.)

## 2 TERMINOLOGY

**AGA** - American Gas Association

**ANSI** - American National Standards Institute

**ANSI Z223.1** - 1992 edition of the National Fuel Gas Code published by American National Standards Institute. Also known as NFPA 54 (National Fire Protection Association pamphlet 54)

**ASTM** - American Society for Testing and Materials

**APPLIANCE (Equipment)** - Any device which utilizes gas as a fuel or raw material to produce light, heat, power, refrigeration, or air conditioning.

**APPROVED** - Acceptable to the authority having jurisdiction.

**ASME** - American Society of Mechanical Engineers

**AUTHORITY HAVING JURISDICTION** - The organization, office or individual responsible for "approving" equipment, an installation or procedure.

**BTU** - Abbreviation for British Thermal Unit, which is the quantity of heat required to raise the temperature of one pound of water one degree Fahrenheit.

**CFH** - Gas flow rate stated in cubic feet per hour. A CFH of natural gas usually contains 1,000 BTU's and LPG contains 2,500 BTU's. Consult your local gas utility for actual BTU content in your area.

**CAN-CGA-B149-1** - Natural gas installation code book used in Canada. Most current edition.

**CAN-CGA-B149.2** - Propane gas installation code book used in Canada. Most current edition.

**CSST** - Corrugated stainless steel tubing

**CONCEALED GAS PIPING** - Gas piping, which, when in place in a finished building, would require removal of permanent construction to gain access to the piping.

**CONNECTOR, GAS APPLIANCE** - A factory-fabricated assembly of gas conduit and related fittings designed to convey gaseous fuel, and used for making connections between a gas supply piping outlet and the gas to an appliance. It is equipped at each end for attachment to standard taper pipe threads.

**DELIVERY PRESSURE** - Gas pressure available after the gas meter.

**DESIGN PRESSURE** - The maximum permitted operating pressure.

**DRIP LEG** - The container (dirt trap pocket) placed at the lowest point in a system of piping to collect foreign materials and condensate. The container must be accessible for cleanout.

**EHD (EQUIVALENT HYDRAULIC DIAMETER)** - A measurement of the relative hydraulic efficiency between different tube sizes. The larger the value of EHD, the greater the flow capacity.

**ELEVATED PRESSURE SYSTEM** - Terms for any pressure above 1/2 PSIG, but less than 5 PSIG.

**EXPOSED GAS PIPING** - Gas piping which will be in view in the finished structure.

**FUEL GAS** - A commonly distributed gas used for fuel such as natural gas, manufactured gas, undiluted liquefied petroleum gas (vapor phase only), liquefied petroleum gas-air mixtures of these gases (included propane and butane).

**GAS UTILIZATION EQUIPMENT** - Any device which utilizes gas as a fuel or raw material or both.

**JOINT** - A connection between two lengths of tubing or a length of tubing and fitting.

**LISTED** - Equipment or materials including a list published by an organization acceptable to the authority having jurisdiction and concerned with product evaluation that maintains periodic inspection of production of listed equipment or materials and whose listing states either that the equipment or material meets appropriate standards or has been tested and found suitable for use in a specified manner.

**LOCKUP PRESSURE, REGULATOR** - The system pressure, immediately downstream of the regulator, at which the regulator valve will completely close (leak tight) under no-flow conditions to prevent the downstream pressure from exceeding a predetermined level.

**LOAD** - The amount of gas required by an appliance, or group of appliances per their manufacturers rating (see CFH definition).

**MANIFOLD** - A fitting to which a number of branch lines are connected.

**MAXIMUM ACTUAL OPERATING PRESSURE** - The maximum pressure existing in a piping system during a normal annual operating cycle.

**METER** - An instrument installed to measure the volume of gas delivered through a piping system.

**NFPA** - National Fire Protection Agency

**PIPING SYSTEM** - As used in this manual, an assembly of corrugated stainless steel tubing and tubing connection fitting, intended for field assembly and installed in residential or commercial building to distribute fuel gas to gas utilization equipment within the building. The piping system may also include a gas pressure regulator(s), shutoff valves, tube shielding devices, distribution manifold(s) and other approved devices or components.

**PRESSURE** - Unless stated otherwise, is expressed in pounds per square inch above atmospheric pressure, i.e. gauge pressure (PSIG).

**PRESSURE DROP** - The loss of static pressure of flowing fuel gas due to friction or other flow resistance in tubing, fittings, valves, regulators or other devices in the piping system.

**PRESSURE REGULATOR** - A valve which reduces and maintains pressure. It automatically opens and closes in response to changing pressure conditions in the downstream piping.

**PSIG** - Pounds per square inch, gauge. The pressure as read from a measurement gauge or device. Gauge pressure is pressure above atmospheric pressure and is sometimes referred to as PSI.

**PURGE** - To completely displace an existing gas with a new gas.

**QUALIFIED INSTALLER** - Any individual, firm, corporation or company which either in person or through a representative is engaged in and is responsible for the installation or replacement of building gas piping systems, who is experienced in such work, familiar with all precautions required, and has compiled with all the requirements of the authority having jurisdiction.

**QUICK-DISCONNECT DEVICE** - A hand-operated device which provides a means for connecting and disconnecting an appliance or an appliance connector to a gas supply, and which is equipped with an automatic means to shut off the gas supply when the device is disconnected.

**REGULATOR, GAS APPLIANCE PRESSURE** - A device placed in a gas line for controlling and maintaining a uniform pressure to the manifold or gas burning equipment

**REGULATOR, PRESSURE** - A device installed/placed in a gas line for reducing, controlling and maintaining the pressure in that portion of the piping system downstream of the device. This device is used in elevated pressure systems and is referred to as a pressure regulator in this manual.

**REGULATOR, SERVICE PRESSURE** - A device installed by the servicing gas supplier to reduce and limit the service line gas pressure to delivery pressure.

**REGULATOR VENT** - The opening in the atmospheric side of the regulator housing permitting the in and out movement of air to compensate for the movement of the regulator diaphragm.

**SHIELDING DEVICES** - A component of the piping system (Floppy-Flex(tm)) used to protect the installed corrugated tubing from accidental puncture by nails, screws or similar hardware at concealed tubing support points.

**SPECIFIED GRAVITY** - As applied to gas, is the ratio of the weight of a given volume to that of the same volume of air, both measured under the same conditions.

**STRIKER PLATES** - A special type of shielding device used when concealed tubing is run through wall studs, floor and ceiling joists or other structural members where tubing movement is restricted.

**TUBING** - ASTM A240 Type 304 Annular Corrugated Stainless Steel Tubing which is bendable and comes in 75 foot coils.

**VALVE, SHUTOFF** - A device used in piping to control the gas supply to any section of the piping system or to an appliance.

**VENT LIMITING DEVICE** - A valve that limits the discharge of gas from a regulator in the event of a diaphragm rupture. Gas discharge is limited to an ANSI approved level. See manufacturer's specifications.

**WATER COLUMN, INCHES** - method of stating pressure measured in inches of water column by a manometer or pressure gauge. Refer to "CONVERSION FACTORS" listed at the beginning of this text.

## 9.2 Limited Warranty

### PRO-FLEX® INTERIOR GAS PIPING SYSTEM

Subject to the terms and conditions contained in this Limited Warranty, Tru-Flex Metal Hose Corp. "TRU-FLEX™" warrants to the original purchaser of the **PRO-FLEX®** Interior Gas Piping System that such product will be free from any defect in material and workmanship for a period of one (1) year from the date of installation. Should any such defects be discovered within one (1) year from the date of installation by a qualified installer the questionable **PRO-FLEX®** part should be returned to TRU-FLEX™ at P.O. Box 247, 2391 So. State Road #263, West Lebanon, IN 47991, (765) 893-4403. If, upon inspection TRU-FLEX™ determines the part to be defective in material or workmanship, then TRU-FLEX™ will furnish a replacement, or at its option, repair the defective part. This warranty does not include the cost of labor for removing and replacing or repairing the defective part nor does it cover the cost of transporting the materials.

This warranty shall not apply to any component part of the Interior Gas Piping system product if it has been installed, altered, modified, repaired or misused, through negligence or otherwise, in a way that in the opinion of TRU-FLEX™ affects the reliability of, or detracts from, the performance of the product. This limited warranty does not cover defects or damage resulting from abuse, neglect, lack of reasonable care, modification or attachment of improper components or devices to this product. Nor does this limited warranty cover replacements to repairs necessitated by loss or damage resulting from any cause beyond the control of TRU-FLEX™ including, but not limited to, acts of God, acts of government, floods and fires.

### INSTALLATION REQUIREMENTS

This limited warranty coverage is subject to and expressly contingent upon the following conditions and limitations; each of the following is a condition precedent to TRU-FLEX'S™ obligations hereunder:

- A. Installation must be performed strictly in accordance with local plumbing and/or building codes, ordinances and regulations and all other applicable laws, and in accordance with the **PRO-FLEX®** Installation/Training Guide and good industry practices. Any deviation from recommended installation or use instructions will nullify this limited warranty.
- B. Installation must be performed by a qualified installer who is recognized as being qualified to install gas piping by local, state, federal or other governmental agencies.
- C. Pressure testing must be performed during rough construction with piping system exposed, all done in accordance with good and safe business practices.
- D. TRU-FLEX™ assumes no responsibility for any system which has been improperly installed.
- E. The purchaser shall be responsible for giving timely written notice of a warranty failure and promptly making TRU-FLEX™ aware of any alleged system deficiencies which purchaser desires to be remedied, all of which shall be done within seven (7) days of discovery of the alleged system deficiency.

### GENERAL CONDITIONS AND LIMITATIONS

The obligation of TRU-FLEX™ pursuant to this warranty is limited, at TRU-FLEX'S™ discretion, to: (a) making a replacement component part available, (b) the repair of the defective component part, or (c) the refund of the purchase price. TRU-FLEX™ shall have no obligation for the furnishing of any labor involved or connected therewith such as the labor required to diagnose trouble or to remove or install any such product, nor does it include responsibility for any transportation expenses or any damages or losses incurred in the transportation in connection therewith.

TRU-FLEX™ shall in no event be liable for other losses, damages, costs or expenses claimed by anyone, whether direct or indirect, and whether arising in contract or tort, including loss from failure of the product to operator for any period of time, and all other direct, indirect, special, incidental or consequential damages, including all personal injury and property damage.

The foregoing limited warranty is in lieu of all other warranties by TRU-FLEX™, express, statutory or implied by law. Without limiting the generality of the foregoing, TRU-FLEX™ makes no warranty of merchantability or fitness of the product for any particular purpose. TRU-FLEX™ neither assumes nor authorizes any person to assume TRU-FLEX™ any other obligation or liability in connection with the sale of the hereinabove referenced product.





Please fill in all blanks to verify you have read and understand all aspects of the installation/training guide and for warranty activation.

PF# \_\_\_\_\_

I, \_\_\_\_\_, Qualified Installer, have read the Pro-Flex®  
please PRINT your name above

installation/training guide and understand all aspects of installation and local plumbing and/or building codes in accordance set forth.

Signed this day \_\_\_\_\_,

\_\_\_\_\_  
signature of Qualified Installer

\_\_\_\_\_  
please PRINT your name above

Contractors Company Name: \_\_\_\_\_

Address: \_\_\_\_\_

Phone Number: ( ) \_\_\_\_\_

NOTE: Return above postcard to: TRU-FLEX METAL HOSE CORPORATION,  
P.O. Box 247 WEST LEBANON, INDIANA 47991

**QUALIFIED INSTALLER CARD**

PF# \_\_\_\_\_

I, \_\_\_\_\_  
date: \_\_\_\_\_  
have read the installation/training guide and understand the **PRO-FLEX®**  
CSST System. I am a qualified installer per my local authority.

*To be shown to the wholesaler when making purchases  
of PRO-FLEX® CSST Tubing and Fittings.*

---

**TO:** TRU-FLEX METAL HOSE CORP.  
PO BOX 247  
WEST LEBANON, IN 47991